

FOREWORD OF ACADEMICIAN A.G. ZAGORODNY, THE PRESIDENT OF THE NAS OF UKRAINE

Dear colleagues! The last year was no less difficult than the previous one. Like the whole country, we had to adapt to different conditions of life and work, mobilize resources, and explore new possibilities.

Since the beginning of the war, our institutions have suffered enormous losses. Russian armed aggression continues to take lives of our colleagues, particularly those who defended the independence of Ukraine on the battlefield.

In 2023, despite all difficulties caused by the war, scientists of the National Academy of Sciences of Ukraine worked actively and hard, producing the results of truly high, international level in many advanced science fields.

Beside conducting basic research in priority science directions, Academy institutions focused their efforts on the aid to the Armed Forces of Ukraine, scientific support to dealing with the issues of high relevance to the state and society, addressing difficult tasks of economic recovery in war and post-war times.

To be sure, most efforts of our scientists go to R&D for strengthening Ukraine's defense capability and security. Last year, over two hundred such developments in the most versatile areas of military applications were demonstrated at a specialized exhibition, which was visited by the state and military leadership of Ukraine.

Extensive work is also done by Academy scholars in socio-humanities. First and foremost, it is addressed at debunking aggressor's ideology, revealing the causes of its emergence and searching for the ways of counteracting it.

Scientists of Academy institutions continue to be actively involved in volunteer activities, both individually and in the framework of various charitable associations.

The implementation of the actions towards reforming the Academy scheduled for 2021—2025 is continuing. The network of Academy's research institutions and organizations was further reorganized. Measures for supporting young scientists were taken.

In spite of all difficulties, international cooperation was advanced and got new impetus. Last year, a series of meetings at a high international level were held, where the achievements of Ukrainian science were presented, various aspects of its functioning under martial law were considered, and possible ways of addressing them were discussed. Numerous programs of supporting scientists from Ukraine that were introduced by the governments and scientific centers of many countries after the beginning of the full-scale Russian invasion were continued in 2023 as well. At the same time, new contests for grants for Ukrainian scholars were announced, in particular, and which is most important, those for conducting research by our scientists here, in Ukraine. The participation of Academy institutions in implementing European programs goes on, they also fruitfully work at expanding bilateral cooperation with international organizations and partners from other countries. It should be noted that our institutions received state-of-the-art scientific equipment as humanitarian aid from leading manufacturer companies of the world.

No doubt, the next year will also be a difficult one. Yet, we are to do everything possible for preserving our leading science schools, retaining human resources. It is necessary to further improve the system of Academy management. Of utmost importance is active cooperation with industrial producers and accelerating the introduction of advanced technologies and developments as much as possible.

At this hardest time for Ukraine, Academy's scientists remain optimistic and do all they can for our victory. I am proud of you and sincerely grateful for your painstaking everyday work, devotion to science and contribution to defending our independence.

Together we will win! Glory to Ukraine!

IMPORTANT EVENTS

The session of the General Meeting of the National Academy of Sciences of Ukraine, summarizing its activities in 2022 and prospects of Academy's further work, **was held on 27 April 2023**. NAS academician Anatoly Zagorodny, President of the NAS of Ukraine, addressed all those present with a foreword and conveyed the greeting of the President of Ukraine Volodymyr Zelenskyi to session participants.

In his speech on the activities of the National Academy of Sciences of Ukraine in the reporting period, Academician Anatoly Zagorodny informed Meeting participants about the activities of NAS institutions in wartime conditions, the challenges the Academy scholarly community was faced with during Russian armed aggression, the losses suffered by the Academy, cited examples of the results of international-quality results of basic research, as well as significant results of innovative applied research and developments of the previous year. He also described the implementation of measures towards reforming the NAS of Ukraine. Summing up, academician Anatoly Zagorodny emphasized the major tasks of the Academy of Sciences in the near future.

Among the priorities he mentioned the retention of research teams, the HR potential, improvement of NAS management system. The emphasis was also on the necessity of dynamic changing research subjects by the institutes in accordance with the current trends of the world science development and nation's needs, maximum acceleration of introducing innovative technologies and developments. Another important task is to involve the maximum aid from foreign partners, restoration and upgrade of Academy's research infrastructure.

Summing up, academician Anatoly Zagorodny noted that the academic community is to do all it can for advancing basic and applied research and implementing its results for enhancing the well-being of our people, strengthening our state and, no doubt, for our victory.

A good tradition of the General Meeting is the annual presentation of the highest award of the National

Academy of Sciences of Ukraine — V.I. Vernadsky Gold Medal. By the results of 2022 contest, this distinction was awarded to NAS academician Volodymyr Gorbulin for his outstanding achievements in developing scientific principles of the national security and defense capability of Ukraine and to professor Janusz Kacprzyk, Foreign Member of the Academy, for prominent works in the field of artificial intelligence, decision-making theory, and robototechnics.

Besides, during the General Meeting session, for the first time the NAS history, B.E. Paton Gold Medal was handed. It is awarded for outstanding achievements in producing S&T developments that have been broadly applied in practice. This honorable award was handed to NAS academician Leonid Lobanov for creating the technology of deformation-free welding of aerospace products and for developing and implementing laser interferometry methods applied in assessing welded joints, and to NAS corresponding member Oleg Korostyliov, Director-General of *Luch* State Kyiv Office, for developing and organizing serial manufacturing of novel weaponry and military equipment.

Summarizing the session, NAS President academician Anatoly Zagorodny noted that the war poses very serious challenges to the country and the Academy, which require timely and effective solutions. One of the major challenges that is in the focus of the Academy Presidium, its sections and departments is the retention of scientific research teams. It is also necessary to continue the work on re-orienting research towards the needs of defense and security, to take an active part in the post-war reconstruction of the country, restoring economy branches and social life.

Presentation of the results of NAS defense R&D to the Armed Forces of Ukraine and Ukrainian central executive bodies. From 29 May to 8 June 2023, the E.O. Paton Electric Welding Institute of the NAS of Ukraine hosted an exhibition presenting defense R&D of NAS institutions. 43 scientific research institutions and organizations of the Academy presented its achievements in the field of state defense and security of the state, military medicine, informational counteraction to Russian aggression, patriotic indoctrination of the Ukrainian military. The majority of the exhibited military products were developed in the framework of implementing targeted R&D programs of NAS defense research.

The exhibition was attended by the commandment of the Armed Forces of Ukraine, the Defense Ministry of Ukraine, the Security Service of Ukraine, heads of ministries and agencies, enterprises of Ukraine's defense industrial complex.

With reliance on the presentation exhibition of defense R&D achievements of the NAS institutions, a catalog of its exhibits was sent to the Council of National

Security and Defense, the Ministry of Strategic Industries, the Ministry of Defense and the General Staff of the Armed Forces of Ukraine. For a more profound insight of the Ministry of Defense and the General Staff of the Armed Forces of Ukraine into defense developments, the Academy sent, in accordance with their demands, additional extended information on the developments presented at the exhibition.

The Jubilee Session of the NAS General Meeting to mark the centenary of the birth of V.M. Glushkov (1923—1982), a prominent scientist, science administrator and public figure was held on 15 September 2023 in Kyiv. Opening the session, NAS President Anatoly Zagorodny noted that it was in Kyiv where the new, cybernetic, stage of academician V.M. Glushkov's activities started. In his foreword, Anatoly Zagorodny focused his attention on the many-year activities of academician V.M. Glushkov, as he was both a prominent scientist, an excellent lecturer, science popularizer and an active public figure, science manager, a leader of numerous large-scale projects of the highest national scope. Besides, academician V.M. Glushkov was a great authority for the world scientific community.

Other presentations made that day were aimed at presenting in full the bright image of academician Victor Glushkov — pedagogue, and an extraordinary personality.

The event was held in a warm and friendly atmosphere, and all its participants had an opportunity to

once again get assured that due to his extraordinary organizing capabilities, broad outlook, wisdom, far-sightedness and the ability to deal with difficult tasks, the name of academician Victor Glushkov is forever present in the history of computer science and technology, and that his scientific ideas produced an immense influence on the next generations of cybernetics scientists.

2023 passed under the sign of the 150th anniversary of Shevchenko Scientific Society (NTSh) — the earliest national public scholarly institution. Established in 1873 in Lviv as a literature society, on the initiative of cultural and public activists of the Dnieper Area and Halychyna, back in 1892 it was reformed into a scientific one. It passed a long and difficult way and made an invaluable contribution to the development of Ukrainian science and culture. With its organizational and scholarly publishing activities, NTSh society filled the gaps in various science fields (especially in Ukrainian studies), influenced the formation of Ukrainian people's national conscience, promoted academic contacts with scholars of other countries, the development of scientific ideas and formation of academic schools recognized in the scientific world.

The 150th anniversary of NTSh was an extraordinary event in Ukraine's scientific and cultural life. Celebration activities on the occasion of this event were held on 8—16 December 2023 and involved sessions, round table talks, presentations, artistic exhibitions, international conferences and other forums. The celebration



Session of the NAS General Meeting

ended with Celebration Academia. All events were held in the mixed format, so all those willing from Ukraine and the world could join them.

On 8 December 2023, in the NAS Major Conference Hall in Kyiv, a jubilee session of the General Meeting of the National Academy of Sciences of Ukraine was held, which was devoted to the 150th anniversary of Shevchenko Scientific Society. It provided a deep insight into the varied NTSh activities during its long history and at the present time, in particular, revealed the role of NTSh in ensuring the incessant progress of the Ukrainian science and implementing its major task — serving to Ukraine, its Resilient People. It was stressed that in today's difficult conditions, NTSh, together with the NAS of Ukraine and other scholarly organizations, is making a significant contribution to counteracting Russian aggression and strengthening national identity.

Opening the Session, the President of the NAS of Ukraine Anatoly Zagorodny noted that the 150th anniversary of Shevchenko Scientific Society is a significant event since that is the earliest Ukrainian scientific organization. Over a long period of its fruitful activities, NTSh, by nurturing Shevchenko's ideas of serving to Ukraine, has made an outstanding contribution to the advancement of Ukrainian science, creating scientific, cultural and educational life in Ukraine and the world.

The NAS Presidium approved by its resolution of 29 November 2023 № 400 the Concept of implementing European principles of open science at the NAS of Ukraine in 2024—2030. The main aim of introducing open science at the NAS of Ukraine is an enhanced presentation of Academy scientists' research results in the open science information space with the use of current technical and information means of assessing such presentation by certain indicators, which will facilitate the scientific community access, both in Ukraine and at the global level, to scientific articles and other scientific results of NAS researchers, science advancement in Ukraine and international scientific co-

operation. The European principles of open science are defined in a number of political documents, EU acts, model agreements.

The resolution of NAS Presidium of 02.11.2022 № 327 'On the NAS participation in implementing the European principles of open science' determined the tasks of implementing the National Plan concerning open science and set up a NAS work group for open science. To ensure the implementation of the abovementioned tasks concerning creating the information resource for an open access to the results of scientific and R&T activities of NAS scientific institutions, NAS Presidium resolutions of 07.02.2023 № 67 and of 30.03.2023 №170 started the implementation of the Targeted S&T Project of the NAS of Ukraine 'Development and implementation of open science infrastructure at the NAS of Ukraine (OPENS)' for 2023—2024.

The concept of implementing the European principles of open science at the NAS of Ukraine in 2024—2030, whose draft version was prepared by NAS group for open science, defines NAS policy in implementing open science: its purpose, principles, priority tasks and main activity directions. The concept was developed with taking into account 'The National Plan Concerning Open Science' approved by the Cabinet of Ministers order of 08.10.2022 № 892-p, which corresponds to key priorities presented in the Road Map on integrating scientific and innovative system of Ukraine to the European Research Area (ERA-UA).

The concept is based on NAS work towards the implementation and introduction of some elements of open science infrastructure and takes into account the experience of institutions and organization of EU member states in open science advancement, as well as its principles determined by UNESCO Recommendation on Open Science and European Union documents.

Concept implementation will allow the formation of the open science model at the NAS of Ukraine in accordance with European principles.

RESEARCH ACHIEVEMENTS. NATURAL AND ENGINEERING SCIENCES

Studies of double β -decay of atomic nuclei

Scientists of the NAS Institute for Nuclear Research in the CUPID-Mo experiment (France), using cryogenic scintillation bolometers, measured with the world-highest precision the spectrum shape and half-life of ^{100}Mo nucleus in respect of two-neutrino double β -decay.

The studies of double β -decay of atomic nuclei are among the most important issues of today's physics, since they enable researchers to investigate the properties of neutrino and weak interaction, search for effects beyond the Standard Model of elementary particles and interactions. But this decay is an extremely rare process, in fact, the rarest radioactive decay known to mankind. So, to register it, scientists employ sensitive detectors situated deep underground for protection against cosmic rays. Those are made of materials with a high degree of purification from the smallest concentrations of radioactive impurities.

One such experiment — CUPID-Mo — is being conducted under the Fréjus mountain massive in the

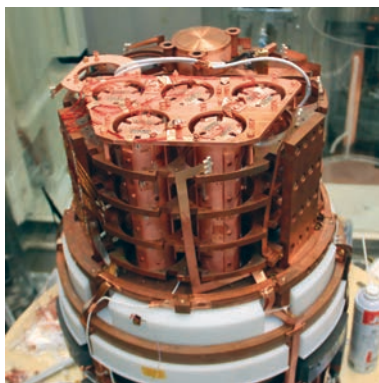

Assemblies with lithium molybdate crystals, mounted in ultra-low background cryostat in Modan underground laboratory in France

French Alps. The electrons emitted in molybdenum-100 nucleus decay are registered with scintillation bolometers made of lithium molybdate crystals, which were proposed by Ukrainian scientists some time ago. Several kilograms of crystals in which molybdenum was enriched with molybdenum-100 isotope to 97% were cooled to nearly absolute zero temperature; this permitted high precision in measuring electron energy to be achieved. At such temperatures, the heat capacity of lithium molybdate is so small that even a single radioactive decay with the energy of several tens of kiloelectronvolts causes a noticeable crystal heating. This change in temperature can be measured with special sensors, and, hence, determine the energy released during the decay, which is extremely small (e.g., a drop of water falling from the height of 1 cm releases a billion times larger energy).

The installation is to function for years to see the effect which, as it had been believed for a long time, cannot be registered at all, since the half-life of molybdenum-100 nucleus in respect of decay mode with the emission of two neutrinos is nearly a billion times larger than the age of the Universe. However, in the experiment that lasted for several years, scientists were able to measure this decay with an unprecedented precision of 1.6%. It is worth noting that even half-lives of the majority of usual β -decays were measured with larger uncertainties. But for the decay without neutrino emission, it was only possible to determine the lower limit of the half-life of 1.8×10^{24} years, which is hundreds of trillion years higher than the time since the beginning of the Universe. As yet, no one has been able to register this decay, although it is the search for it that was the main aim. As scientists are hopeful not only to measure the mass of neutrino, determine, at last, the mass state diagram of neutrinos and prove the existence of a new type of matter (when a particle is identical to its antiparticle) but also to explain one of the major mysteries of today's science concerning the baryonic asymmetry of the Universe: why do we observe matter without the equal amount of antimatter in the Universe? Since without this mysterious asymmetry only the dark matter and light would remain in the Universe, there would be neither stars nor planets.

The research aimed at developing a much more sensitive installation, with the crystal mass of several hundred kilograms, is going on. Scientists hope to see at last this extremely important for theoretical and experimental physics decay, which is the key to explaining the processes that during Big Bang led to the baryonic asymmetry of the Universe, i.e. to its current state when matter prevails over antimatter.

F. Danevich, M. Zarytskyy, V. Kobychiev, O. Polischuk, V. Tretyak

New forms of strong-interaction matter in relativistic nucleus — nucleus collisions

Strong interaction is one of four fundamental interactions described by quantum chromodynamics (QCD); its elementary particles are quarks and gluons. Studying the phase structure of strong interaction matter is one of the important areas of today's high energy physics. Scientists' experimental and theoretical efforts are now aimed at analyzing different phases, phase transitions and possible critical points in the matter formed in relativistic nucleus — nucleus collisions. The evolution of systems emerging in relativistic collisions of heavy ions is characterized with extremely high matter temperature and density, an extremely small size and

short life-time, as well as the highest expansion rates known in nature. This is an exceptionally interesting and difficult object to be investigated. In recent years, the primary attention of scientists has been focused on the correlations of hadrons born in high-energy collisions and on the fluctuations of their numbers from event to event. These observable values are sensitive to QCD equation of state and its phase structure.

In their studies of the fluctuations of conserved charges, scientists of Bogolyubov Institute for Theoretical Physics of the NAS of Ukraine obtained analytical expressions that give the relation between experimentally found charge fluctuations and the respective results of large canonical ensemble. Numerically, these formulas determine the effect of charge conservation laws and

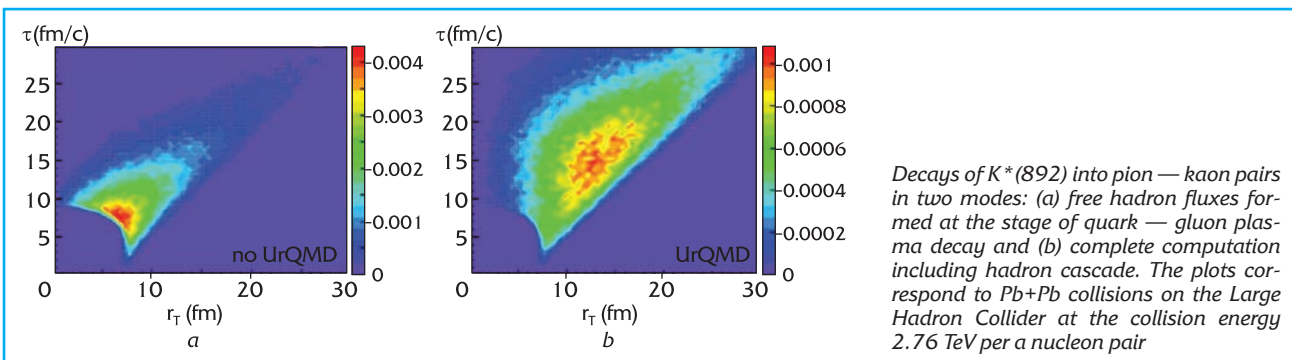
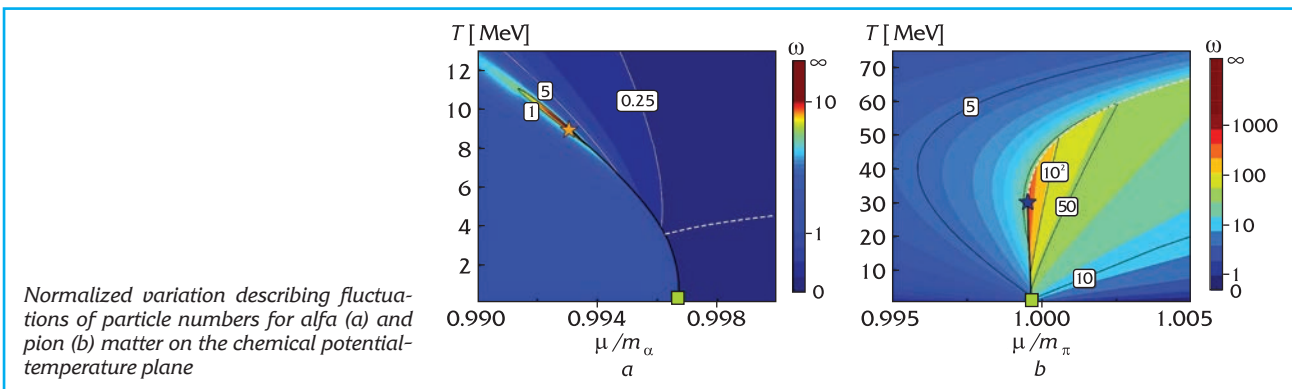
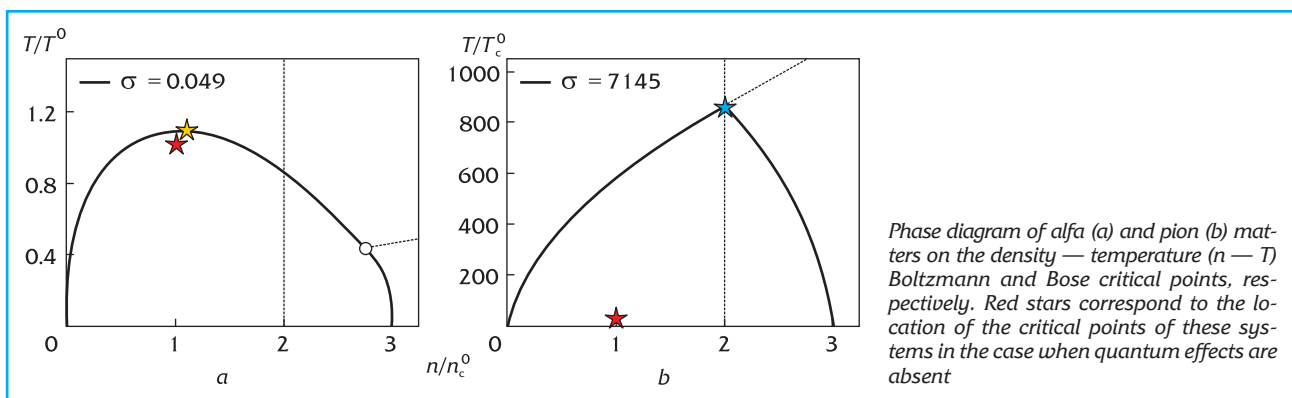

are an important step towards the direct comparison of theoretical models and experiment.

The system of π -mesons in the Bose condensate state is an exotic phase of matter, which can be generated in particle collisions during experiments on the Large Hadron Collider. Such statistical system was studied in the framework of mean field models. Two physical phenomena are possible: liquid — gas first order phase transition and Bose — Einstein condensation. The relation between these two phenomena depends on the parameters of mean field potential and boson masses. Found for the first time were two types of critical points that belong to different universality types with different sets of critical parameters.

Researchers studied two-particle functions of pion correlation for proton — proton high-multiplicity collisions on Large Hadron Collider, where quark-gluon plasma can be generated. The main feature of the systems born in such selective high-multiplicity collisions was determined and analyzed: a very small transverse radius that causes high density of the system, which leads to the small-volume quantum phenomenon — Bose — Einstein condensation at very high temperatures. The study showed that such condensation can be observed experimentally.

The emission times of pions from the fast-expanding quark — gluon and hadron systems during nucleus — nucleus collisions were computed. These periods proved to be systemically shorter than those for kaons. The explanation of these results is related to the fact that after quark — gluon phase the matter for a long time stays in the hadron phase. The formation of K^* resonances and their decays into kaons in the hadron environment leads to an increase in emission duration.

Both final and complete space — time pictures of matter evolution during nucleus — nucleus collisions were investigated. With this purpose, the emission of photons for which hadron environment is "transparent" was analyzed. Photon emission can be directly recorded in the experiment at any stage of the process, in particular, that from quark — gluon matter. In the investigations of photon emission, the durations of all stages of nuclei collisions were determined. Researchers also found the significant influence of photon emission from the process of quark — gluon matter deconfinement during system expansion to photon spectra, and their azimuthal anisotropy.

M. Gorenstein, Yu. Sinyukov

Blue depression in the optical spectra of M dwarfs

In the vicinity of the Sun, dwarf stars of late spectral classes are the majority. According to the latest data of the Gaia mission, nearly 61% within 10 pc radius are

M dwarfs, and half of those belong to spectral classes from M3V to M5V. Due to the emission maximum of such stars being in the red and infra-red spectrum ranges, the majority of their spectra studies were focused on observations in the region of long (more than 1 μm) wavelengths, where exact identification of spectrum details is quite probable. Spectra of cold dwarfs in the optical range are mainly formed by absorption of TiO molecule, but at wavelengths shorter than 4500 \AA , where TiO lines disappear, it is possible to obtain information on the state of deep and relatively hot photosphere strata in which absorption lines of many atoms are generated. But since the emission flux in blue spectrum range is rather weak for M dwarfs, there are problems both with observation and modeling of these spectra.

A team of scientists from Ukraine (the Main Astronomical Observatory of the NAS of Ukraine), Great Britain, France and Australia discovered and analyzed a broad depression (an anomalous drop of emission flux) in the 4000—4500 \AA wavelength range. This spectral feature is enhanced in the dwarf stars of later classes and is sensitive to star gravitation and metallicity. The depression centered on the neutral calcium resonance line at 4227 \AA reduces the intensity of neighboring spectral lines by approximately two orders in comparison with the predicted one. Several possible mechanisms leading to such depression were considered, namely: the effect of temperature, gravitation, metallicity, dust, constant attenuations, and atmosphere stratification. Also considered was the effect of molecular opacities that generate spectra of AlH, SiH, and NaH molecules in this range. Emission absorption in the wings of CaI resonance line was shown to be the most probable cause of M-dwarf blue optical depres-

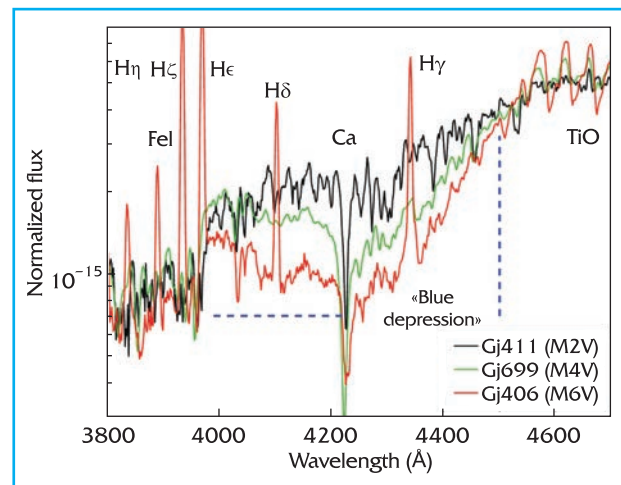

Spectra of M dwarfs GJ411 (M2), GJ699 (M4), and GJ406 (M6) from the Sun's vicinity, which demonstrate blue depression in the 4000—4500 \AA wave range. Hydrogen emission lines can be seen in the spectrum of GJ406, which suggests a relatively young age of the star

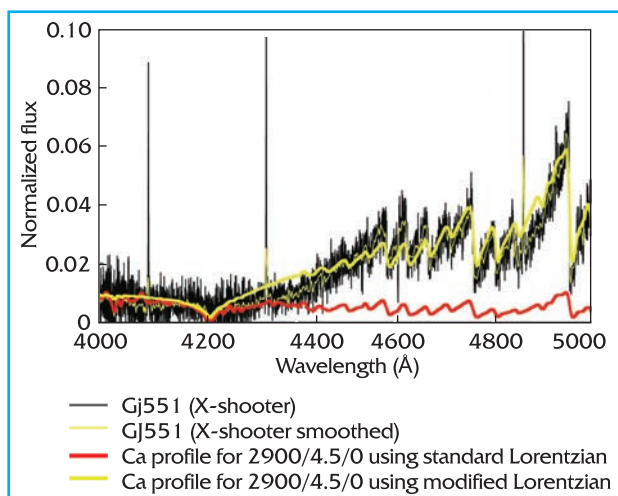

Comparison of synthetic spectrum with modified Lorentzian of the CaI resonance line (solid yellow line) with observation spectrum of GJ551 (M5.5V), obtained on the X-shooter (ESO, VLT) spectrograph (black line). The red line on the plot shows that the synthetic spectrum calculated with standard Lorentzian for CaI does not allow energy distribution in the 4000–4500 Å range to be displayed

sion. An empirical form of modified Lorentzian for this atom line was proposed as promising for use. Its wide wings in the case of calcium line in M-dwarf spectra are increased with the drop in their effective temperatures below 3500 K and are similar to broad spectral lines of sodium and potassium, which form the structure of the red region of L-dwarf optical spectra.

H.R.A. Jones, Ya. Pavlenko, Yu. Lyubchik, M. Bessel, N. Allard, D. J. Pinfield

GeSn-based optoelectronics: fundamentals of band-structure deformation engineering

In the dynamic word of advanced technologies, optoelectronics based on stanogermanides is rapidly developing as a revolutionary element that can change its potential. These, at first sight complex, alloys are the keys to the progress in combining light and electronics since they offer matchless versatility and performance.

GeSn is prominent among a very large number of semiconductors due to the controlled width of its band gap. This unique property permits such compounds to be able either to conduct current, like a metal, or insulate, like a dielectric. Such versatility opens up a number of opportunities, especially in the area of infrared (IR) technologies, where traditional semiconductors such as silicon are quite limited.

IR technologies are widely known, primarily, in thermal imaging and telecommunication applications and are developed due to the possibility of controlling IR

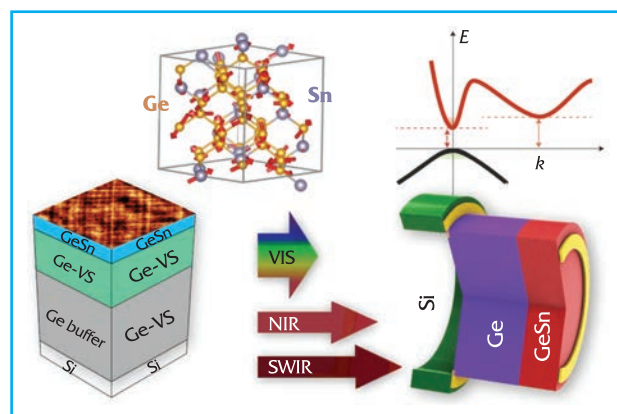

Schematic image of semiconductor structure of the wide-band sensor based on GeSn alloys

radiation. GeSn alloys, due to the precision engineering of their band structure, are ideal for producing sensitive IR detectors and effective IR lasers in the required spectrum ranges. This technological breakthrough opens a new stage in various areas, including the improvement of high-speed Internet with fiberoptic networks and the development of high-precision thermal imagers for medicine and environment monitoring.

The use of GeSn in military equipment is of special interest. High sensitivity and precision of GeSn detectors can significantly enhance the potential of night vision equipment, which is of utmost importance for surveillance and remote reconnaissance missions. Besides, the development of compact, highly effective IR lasers will be instrumental in improving aiming systems, ensuring both strategic and tactical advantages on the battlefield.

Despite highly promising prospects, limitations in the stability and efficiency of GeSn structures production stand in the way of their wide application. However, extensive research and new technological ideas are gradually and steadily overcoming those obstacles. In particular, to deal with challenges of deformation engineering of germanium band structure, scientists of V.Ye. Lashkaryov Institute of Semiconductor Physics of the NAS of Ukraine elaborated methodological principles of ultra-sensitive nanoprobe control of the mechanical parameters of GeSn alloy nanometer epitaxial layers. With methods of atomic force indentation and high-resolution X-ray diffractometry, Institute's research associates for the first time ever discovered and explained the anomalous dependence of the elasticity modulus of these alloys produced by chemical vapor deposition on the tin content in nanometer films. It was found that the redistribution of residual elastic strain fields and the configuration of structural defects can, at temperature change, cause anomalous changes in photoconductivity and reduce the width of di-

rect-gap transition in relaxed $\text{Ge}_{85}\text{Sn}_{15}$ structures. The results obtained are important for developing novel optoelectronic devices of mid-IR range, based on $\text{GeSn}/\text{Ge}/\text{Si}$ with the use of established CMOS technologies of integral circuit production.

P. Lytvyn, A. Kuchuk, H. Stanchu, V. Lysenko, S. Kondratenko

Nanocomposites based on partially unzipped carbon nanotubes

Scientists of V.I. Vernadsky Institute of General and Inorganic Chemistry of the NAS of Ukraine synthesized a new hybrid nanocomposite based on partially unzipped multilayered carbon nanotubes (PUMLCNT) and graphite-like carbon nitride $\text{g-C}_3\text{N}_4$. They developed an electrochemical method of PUMLCNT synthesis (7–9 layers, diameter 8–10 nm), which consists in electrochemical oxidation of carbon nanotubes in an acidic solution. The degree of nanotube unzipping was controlled by current density and amounted to $\Theta = 30\text{--}70\%$. Nanoparticles of $\text{g-C}_3\text{N}_4$ (≤ 1 nm) were produced by thermochemical synthesis from urea and melamine with various component ratios during synthesis. On the basis of IR absorption spectra, it was determined that for $\text{g-C}_3\text{N}_4$ there are only C–N and C=N bonds, as well as vibrations of triazine ring as a whole. CH bands were also observed, which was due to the presence of defects and vacancies in the structure. After composite with PUMLCNT is formed, the IR absorption spectrum changes radically: absorption increases in 1160 cm^{-1} , 1114 cm^{-1} , 1063 cm^{-1} regions, which is not characteristic of $\text{g-C}_3\text{N}_4$ and is caused by composite formation. The synthesized composite was studied as a catalyst for oxygen fuel cell electrode. This nanocomposite was found to be close, in terms of its performance characteristics, to oxygen electrodes based on platinum-containing materials.

Photosensitive nanocomposite containing PUMLCNT and titanium dioxide nanotubes was formed by electrochemical method and by electrophoresis. Light ab-

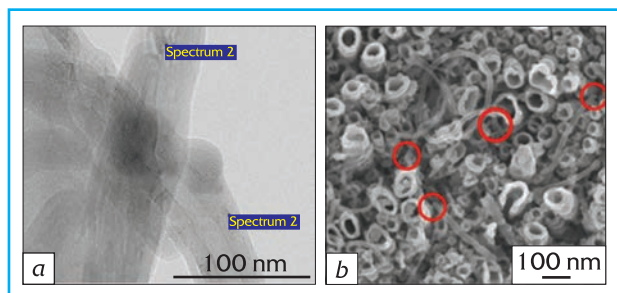

Microphotographs of the composite with partially unzipped multilayered carbon tubes and $\text{g-C}_3\text{N}_4$ (a) and $\text{NT-TiO}_2/\text{PUMLCNT}$ (b), $\Theta = 50\%$, where red circles show TiO_2 -introduced PUMLCNT $\Theta = 40\%$

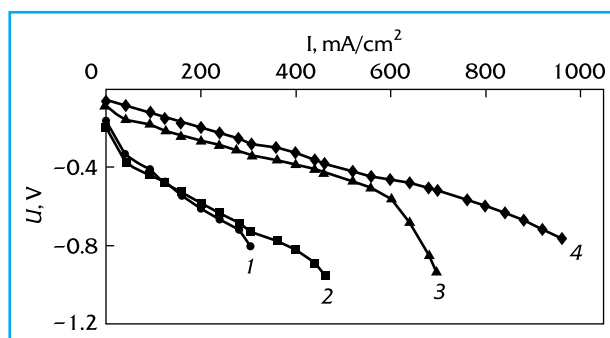

Current-voltage characteristics of oxygen electrodes with the active layer made of various electrode materials: 1 — PUMLCNT $\Theta = 50\%$; 2 — $\text{g-C}_3\text{N}_4$; 3 — composite C_3N_4 with PUMLCNT $\Theta = 50\%$; 4 — PUMLCNT with applied Pt in the amount of 10 mass % and $\Theta = 50\%$

sorption by NT-TiO_2 structure occurred in the ultraviolet spectrum region, while absorption spectrum of the nanocomposite was significantly extended to visible spectrum region. It was revealed that the location of energy bands for PUMLCNT and NT-TiO_2 facilitated effective barrier-free charge phototransfer in the nanocomposite. Besides, the separation of photogenerated carriers was improved, their activity in the subsurface layer of nanotubes increased, which makes this nanocomposite effective in obtaining “solar” hydrogen.

The above results show that partially unzipped carbon nanotubes can be effectively used for producing various nanocomposites for different purposes: in sensor devices, systems for obtaining “solar” hydrogen, oxygen electrodes of chemical current sources etc.

G. Kolbasov, M. Danilov, I. Rusetskyi

Resistive switching in point contacts of transition metal dichalcogenides

Scientists of B. Verkin Institute for Low Temperature Physics of the NAS of Ukraine, in collaboration with German materials scientists from Leibniz Institute for Solids and Materials (Dresden), in their recent studies of the dichalcogenides of transition metals (TM) have discovered the effect of resistive switching in a number of PM layered ditellurides. Resistive switching is a physical phenomenon when a specimen suddenly changes its resistance under the influence of applied voltage or current. It was demonstrated that a submicron point contact based on WTe_2 , MoTe_2 or TaTe_4 ($T = \text{Ir, Rh, Ru}$) can reversibly switch its conductivity type from metal to semiconductor under the action of applied voltage. The research was based on the microcontact spectroscopy method discovered 50 years ago by NAS academician I.K. Yanson. With high current density and electric field strength, it permits studies of materials properties on the interface in limited geometry from submicron to nanometer range.

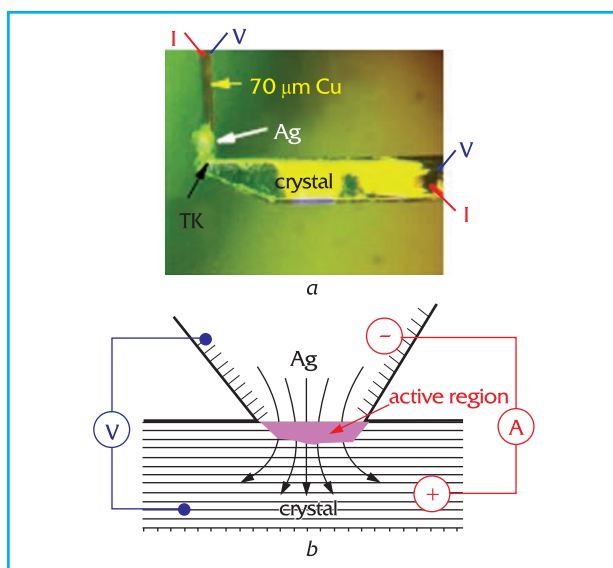

Photograph of point contact (PC) between the specimen and silver (a). Model of PC between the tip and Ag tip, where shown in red is the "region" of the maximum electric field concentration (b). The arrows show current propagation in PC

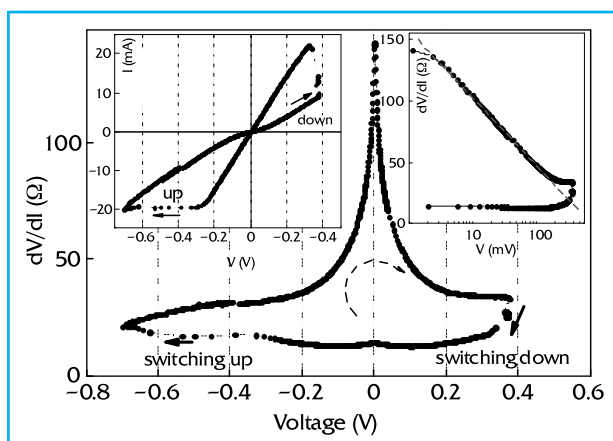

Differential resistance dV/dI and BAX (left-hand insert) of PC between Cu_xTiSe_2 specimen and silver electrode at "helium" temperature 4K. The right-hand window shows the "logarithmic" behavior of dV/dI

The research was continued on TM selenide family: $TiSe_2$, $TiSeSi$, Cu_xTiSe_2 , where resistive switching effect was also found and observed in a wide temperature interval from helium to the room temperature, with a change in conductivity by several orders of magnitude. Self-switching is considered to be due to the violation of the stoichiometry of point contact core due to the drift/displacement of Se/Ti ions/vacancies in a strong electric field realized in submicrometer contacts. I.e., strong electric field causes a local modification of crystal lattice, which changes the type of material conductivity from metallic to that of semiconductor. In this case, the opposite polarity voltage removes the distur-

tion, which restores the metallic structure. Thus, a point contact acts as a memristor, i.e. the resistor that "remembers" the voltage applied to it. This opens ways to employing the abovementioned materials in nanoelectronics and computers, e.g., in upgrading the resistive memory with random access ReRAM or in developing novel types of logical elements for the advancement of neuromorphic engineering. The effect of resistive switching by means of Yanson contacts enables researchers to develop a simple and affordable method of fast search for and characterization of materials that can be used to produce more effective, energy-efficient and flexibly scaled electronic devices.

D. Bashlakov, O. Koitnitska, S. Aswartham, Yu. Shemerliuk, H. Berger, D. Efremov, B. Büchner, Yu. Naidyuk

Assessing the risks of negative environment changes by the data of Earth remote sensing

Researchers of the State Institution 'Scientific Centre for Aerospace Research of the Earth' of the Institute of Geological Sciences, the NAS of Ukraine, in collaboration with their partners from the University of Zilina (Slovakia), developed theoretical and methodological basis for assessing the risks of negative environment changes and for taking further measures to prevent socio-economic and climatic hazards. With reliance on multi-scale data of Earth remote sensing (ERS) obtained from numerous sources, a multifactor assessment of land degradation risk was carried out for mountain landscapes of the Pieniny National Park (Slovakia). The risk was calculated on the basis of quantitative determination of land degradation factors that can be assessed remotely, viz.: terrain slope, vegetation cover, and soil surface moisture. Four risk levels were used for the map. The probability of danger was calculated on the basis of analyzing time series of ERS data. So, the accuracy of this map depends on both risk determination and initial preliminary processing of ERS data, which affects the calculation of danger probabilities.

Fire danger was also assessed using ERS data. The methodology developed combines time series of the components related to fire process, while risk analysis is performed according to hazard functions. The proposed approach was checked for natural and semi-natural mountain landscapes of the Eastern Carpathians on the Slovak — Ukrainian border, within Polonyny National Park (Slovakia) and Uzhanskyi National Nature Park (Ukraine). The compiled map of fire risk for which four grades were used: high, existential, potential, and absent, was validated with reliance on FIRMS NASA fire data archive.

The results of the work are of major importance for improving the efficiency of assessing the risks of ne-

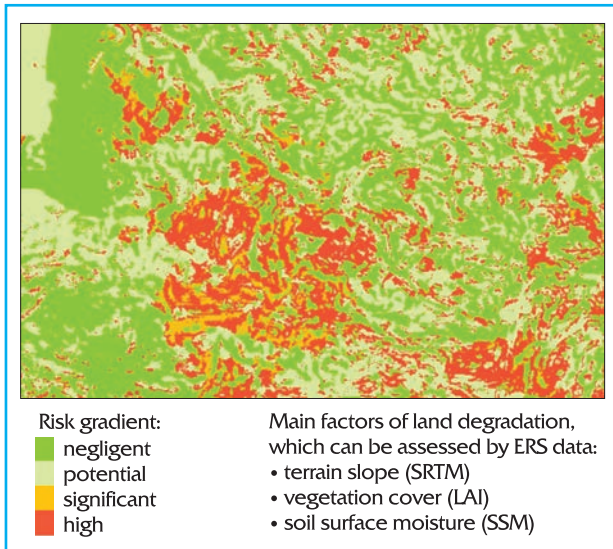

Assessing and mapping the degradation of mountain lands

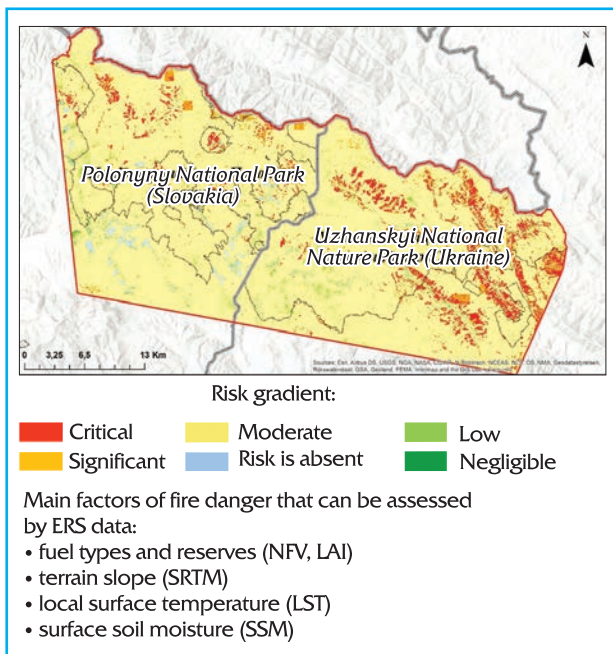

Mapping and assessing fire danger in natural and semi-natural mountain landscapes of the Eastern Carpathians within the limits of Polonyny National Park (Slovakia) and Uzhanskyi National Nature Park (Ukraine)

gative environment changes with reliance on multi-scale Earth remote sensing data obtained from various sources, preparing proposals towards measures for prevention of socio-economic and climatic hazards. They will be instrumental in obtaining the agreed information on possible environmental hazards as a basis for further integration to the decision-making systems and for sustainable development of territories.

S. Stankevich, A. Kozlova, A. Andreiev, A. Lysenko

Wave disturbances from solar terminator according to the measurement data of terrestrial network of VLF radio signal receivers

Scientists of the NAS Space Research Institute and the State Space Agency of Ukraine, jointly with their colleagues from Great Britain (Sheffield University), studied the characteristics of wave disturbances from solar terminator, using measurement data of the terrestrial network of receivers of very low frequency (VLF) radio signals. The existing global network of VLF radio stations allows systemic studies of the atmosphere and ionosphere at the altitudes that are hardly accessible to other experimental research methods. In particular, the data of these measurements can be used for systemic monitoring of atmospheric wave activity on the global scope.

A procedure was developed for approximate calculation of neutral atmosphere density fluctuations caused by the propagation of acoustic-gravity waves (AGW), relying on radio signal amplitudes on relatively short radio routes (less than 1500 km). Researchers analyzed physical mechanisms of the effect of acoustic-gravity waves on the amplitudes of VLF radio signals. The propagation of VLF signals was shown to influence radio wave amplitudes mainly through the change in the level of their reflection from the ionosphere. In the geometric optics approximation, correlations were obtained that permit AGW amplitudes to be approximately determined by amplitude fluctuations. The procedure developed was tested on several European radio routes. Using these results, acoustic-gravity wave characteristics were determined at the altitudes of radio signal reflection.

By the data of measuring the amplitudes of VLF radio signals, the disturbances from solar terminator in

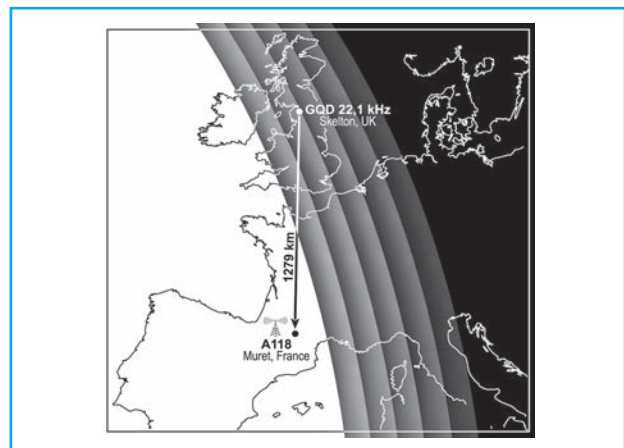

Location of GQD-A118 VLF radio route (Great Britain — France) in relation of solar terminator

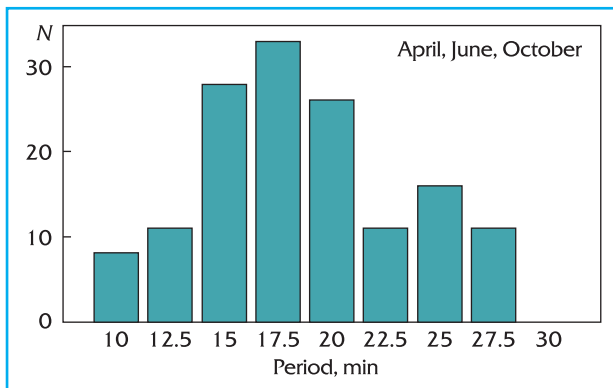

Distribution of wave disturbance periods with relative amplitudes in excess of 3% on the evening terminator

the range of medium-scale AGW from ~5 min to ~1 hr. were investigated. The data of measuring VLF wave amplitudes on mid-latitude route GQD-A118 (Great Britain – France) were used. On the route considered, a systemic rise in wave fluctuation amplitudes was recorded during several hours after evening terminator passage. Observations of radio signal amplitude fluctuations were carried out for four months: April, June, October of 2020 and February of 2021. For various seasons, the prevalence of terminator waves with periods of ~15—20 min was found. The energy balance of these disturbances was analyzed and the conclusion concerning their quasi-horizontal propagation was made. The results obtained show the predominance of wave harmonics on the solar terminator, which meet the condition of synchronism with this moving source.

O. Chermnykh, A. Fedorenko, A. Voitsekhovska, Yu. Selivanov, I. Ballai, G. Verth, V. Fedun

Maneuverable power plant based on small-size modular reactor

Scientists of A. Podgorny Institute of Mechanical Engineering Problems of the NAS of Ukraine proposed a concept of developing and a schematic design of

promising maneuverable power plant (MPP) based on small-size modular reactor (SMR), which is capable of electric power accumulation. The principal novel solution concerning the technological scheme of SMR-based MPP is the organization of its work in nominal and peak modes, which are radically different in terms of their thermodynamic cycle. In the nominal mode, the steam turbine unit operates in the thermodynamic cycle with steam separation, while in the peak mode — without it, due to increased temperature of fresh steam as a result of hydrogen and oxygen combustion.

The unique nature of the proposed SMR-based MPP with the system of power accumulation is in combining innovative technologies of hydrogen generation under high pressure with novel approaches to its use in current steam turbine units. To implement the system of power accumulation, researchers proposed to involve hydrogen technologies for accumulating “surplus” energy generated by the power unit during night off-peak hours (MPP nominal operation mode) with its further return to the system in peak consumption hours due to using the generated hydrogen and oxygen by high-efficiency combustion systems and the steam turbine (the peak the mode of MPP operation). The proposed solutions make it possible to provide the return ratio of the accumulated power at the level of 70%, which is the highest of all approaches known in the world (except that of pump storage stations).

To analyze the possibility of its introduction into domestic energy industry, the most promising 45 MW NuScale SMR, developed by NuScale Power Corporation (USA), was chosen. With reliance on current methods of optimization and thermodynamic analysis, a thermal diagram of steam turbine power unit was proposed. It permits an increase in electrical efficiency from the 28% announced by the manufacturer to 32.8% in the nominal operation mode. For MPP operation in the peak mode, the thermal scheme was complemented with a hydrogen combustion chamber installed after SMR, which permits supplying steam tur-

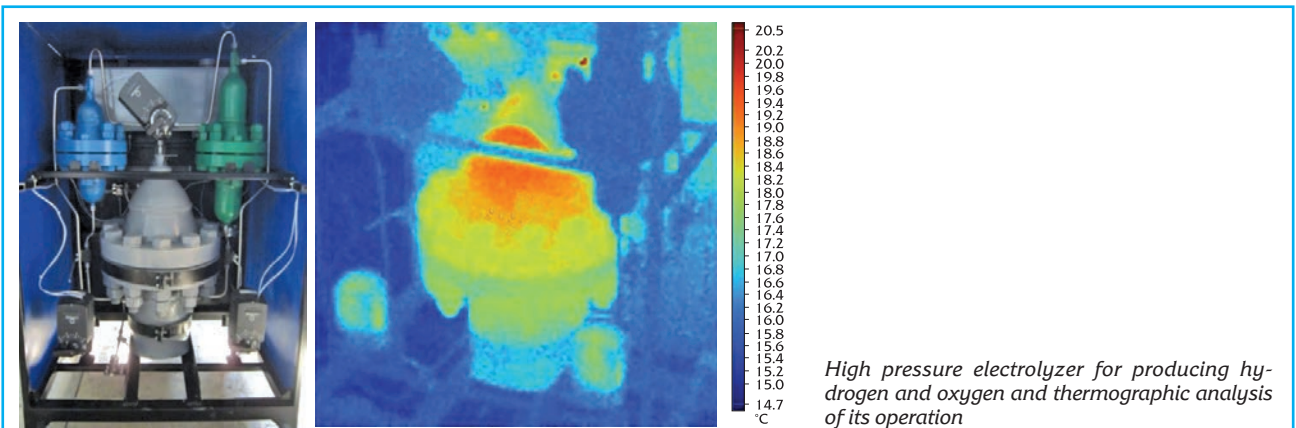

High pressure electrolyzer for producing hydrogen and oxygen and thermographic analysis of its operation

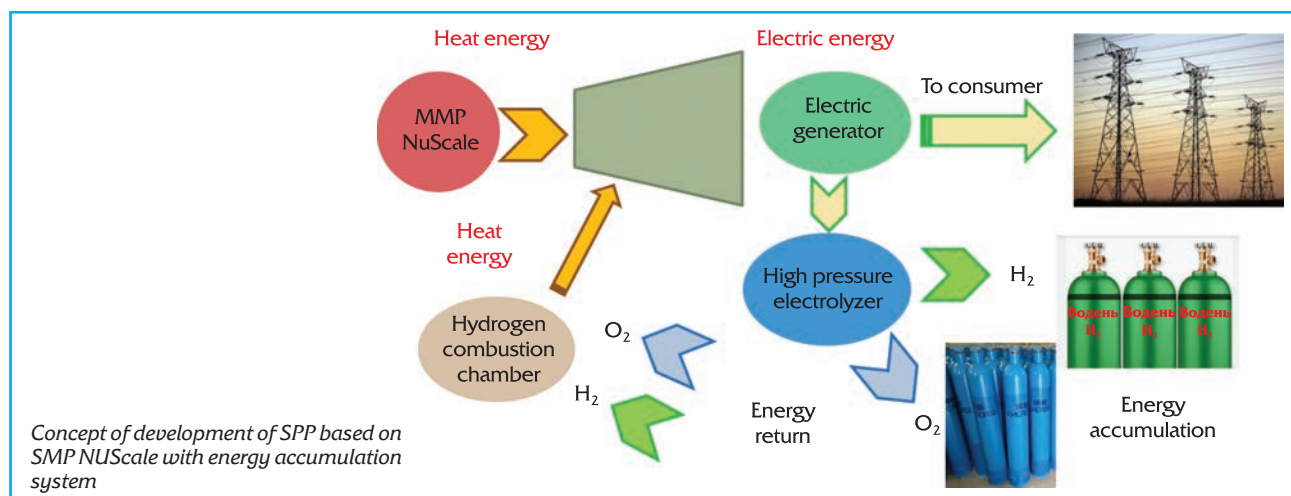

bine with superheated steam of a higher temperature than that in the nominal mode. The MPP electric efficiency during its peak mode operation is 34.8%.

The use of SMR-based MPP with energy accumulation systems will reduce the reliance on the use of imported fossil hydrocarbons in the total amount of primary fuel and ensure sustainable power system functioning, as well as be beneficial to environment conservation and improvement.

A. Rusanov, A. Kostikov, V. Solovey, V. Tarasova

A new biological role of $\alpha 7$ nicotine acetylcholine receptors

Researchers of Palladin Institute of Biochemistry of the NAS of Ukraine investigated the mechanisms of the involvement of $\alpha 7$ subtype of nuclear membrane nicotine acetylcholine receptors in neuroinflammation regulation. The bond of these receptors to cell nuclear pore proteins was revealed, and it was shown that HIF-1 α transcription factor and p65 phosphorylated subunit of NF κ B nuclear factor, which activate nuclear membrane inflammation and hypoxia processes, are

bound to $\alpha 7$ nicotine receptors of nuclear membrane. In particular, it was determined that nicotine receptor activation by an agonist prevents bonding of the above-mentioned factors to the nicotine receptor of nuclear membrane and their translocation to the nucleus, disrupting the development of pro-inflammation and hypoxia processes. It was demonstrated in an *in vivo* model that introducing the agonist of $\alpha 7$ nicotine receptors into APP43PS1 transgenic mice, which are characterized with an increased inflammation level, actually is the acknowledged Alzheimer disease model. It improves cognitive functions of animals and retards the accumulation of pathogenic amyloid-beta ($A\beta 1-42$) in their brains.

The data obtained are the first to demonstrate the involvement of $\alpha 7$ nicotine receptors in the translocation of transcription mechanisms to the nucleus, which can account for one of the mechanisms of the cholinergic ligand anti-inflammatory action, as well as a significant role of activating $\alpha 7$ nicotine receptors in preventing pathological symptoms of experimental Alzheimer disease.

M. Skok, O. Lykhus, O. Kalashnik

RESEARCH ACHIEVEMENTS. SOCIAL SCIENCES AND HUMANITIES

Scholars of the Section of Social Sciences and Humanities of the NAS of Ukraine carried out a significant amount of research in economics, socio-political and cultural development of the Ukrainian society in the conditions of Russian war against our country.

Scientists of the State Institution 'Institute of Economics and Forecasting of the NAS of Ukraine' made a quantitative evaluation of the consequences of uneven development of the global economy and their impact on Ukraine, proved the possibility of a significant reconfiguration of its structure in the context of individual economies, their groupings and associations / coalitions. They justified high probability of aggravated economic disputes against the background of the fight for global superiority. And the severity of such confrontation will be seen both on the part of the key "pursuing" state (China) and the current leader (the USA).

Trends in the global GDP production, world population dynamics, workforce and its productivity across countries and their groupings were assessed; evaluated was global GDP dynamics on 10-year horizon according to two scenarios: extrapolation and "trend-driven" one, on condition of a slowdown in GDP growth; some substantial changes in China's economy, their potential meaning for PRC global positioning and its competitive capacity, respective potential consequences for the development of international relations in the economic sphere were determined, with the risks of non-competitive escalations taken into account.

It is important for Ukraine to take into account endogenous factors of providing economic and financial stability; first and foremost, the strength of currency regulation instruments in securing the financial sphere of economics from external shocks should be considered.

During strategizing the economic development of Ukraine and its positioning in the sphere of international relations, it should be taken into consideration that poor and the poorest countries will stay in the "low-income trap" in the next decade. They will not be able to avoid it. The population of such countries will grow on absolute and relative scales. That will enhance migration crises and the tension between global South and North. The confrontation between the USA and China will not contribute to solving these problems at the international level. Stabilization loans and humanitarian

aid will play the role of "short-term anesthesia", while the radical therapy would require the development of state institutions and regulatory capabilities.

S. Korablin, V. Sidenko, I. Lunina, Ye. Bublyk et al.

The Institute of Sociology of the NAS of Ukraine published the book "**Ukrainian Society in the Conditions of War. Year 2023**". The undeclared Russian war against Ukraine led to large-scale and controversial changes in social processes, in moods, aspirations, political preferences and priorities of Ukrainian citizens. Along 2023, professional sociologists analyzed and interpreted empirical data acquired in the first year of war. Observation results are presented in ten chapters of the book, while its principal part consists of generalizations and conclusions that are mainly based on the materials of monitoring the changes in the structures and everyday life of the country's population in 2022—2023.

The aim of the team of authors was to understand how the society is modified in war conditions and how accurately that is recorded by the available methodological and procedural instruments. I.e., what is the new reality that gradually / suddenly demonstrated itself today, and whether researchers possess a set of concepts and methods which provide reliable knowledge.

Such statement of the issue in socio-political terms also advances methodological tasks without whose solution the sociological monitoring of the Ukrainian society cannot fully follow the status of dynamic equilibrium between the building of modern civic state and the reactional resistance of patronal networks that are now dominating Ukrainian politics. This is concerned with two highest-priority tasks of methodological nature. The first is the extension of monitoring instruments due to the means for recording the state and effects of national-public fragmentation, which, in essence, is a moderately destructive form of social heterogeneity. Of no less importance is the other task — the fragmentation of procedures that would assess the socio-cultural dominant trend, its social status and alternatives in the space of public opinion.

Ye. Holovakha, S. Makeev, S. Dembitskyi, O. Zlobina, N. Kostenko et al.

Scholars of the NAS Institute of the History of Ukraine prepared and published the monograph "**The War of Russia against Ukraine and International Community**". This popular-science edition presents the characteristic of war as a social history phenomenon and, relying on rich factual material, analyzes the dynamics of changes in the politics of European, North and South American, Asian and African countries regarding the war of Russia against Ukraine in 2014—2023. It shows how the politics of the states of "old" and "new" Europe has been transformed since the beginning of the hybrid war and, later, since the wide-scale Russian

aggression against Ukraine, with all conventional weapon types being used. The dynamics of US and Canada politics concerning Russian-Ukrainian war is shown. The authors consider the peculiarities in the attitudes of China, India, Argentina, Brasil, South-African Republic and some other countries of Africa, Asia and South America towards this war in the center of Europe. They analyze the causes and effects of "neutrality" politics of some countries in respect of the RF armed aggression against Ukraine. Also shown is the evolution of the EU, NATO, OSCE, UNO politics in respect of this war, as well as the activities of Ukrainian diplomacy in defending the sovereignty and territorial integrity of the country and in curbing Russian armed aggression, which is a threat for the whole democratic world.

S. Vidnyanskiy, A. Martynov

The monograph "To Freedom Through Fire: Ukraine Against Rushism". was published. The book analyzes the origin and evolution of "Russki mir" ("Russian world") and investigates how Russia has failed the task of post-totalitarian transit and instead of healing the wounds of communo-bolshevism has transformed into a novel totalitarian system; what are the foundations of Russian imperialism revival and what components it consists of; how the revival of its empire has become Russia's new-old national idea; how the political technology of "Russki mir" has become the basis of rashism; why the genocide of Ukrainians has acquired novel historical forms; why collective Putin considers Ukraine as the front of ontological battle between Europe and Eurasia; if there still remain preventive measures against the growth of mass militarist psychosis; finally, how to overcome the ontological evil and firmly shut the gate of the abyss.

The system analysis of socio-economic, socio-political, and ethno-cultural bases of "russki mir" political technology transformation into a novel neo-totalitarian doctrine, the change of the post-soviet RF into a neo-totalitarian system, which is carried out in the monograph, is of primary importance for developing the means of effective counteraction to rashism expansion and establishing a new world order that would be able to adequately respond to new global challenges.

The author shows against the broad background of global trends and circumstances of the post-soviet transit in Russia that the novel Russian totalitarian system (rashism) has been created and exists as the image and likeness of a modernized version of the imperial prison, i.e. GULAG.

L. Yakubova

The first book of vol. 9 of the "History of Ukrainian Literature" in 12 volumes, was prepared and published by Shevchenko Institute of Literature of the NAS of Ukraine. It was issued by *Naukova Dumka* Publishers.



The edition considers new phenomena and figures in Ukrainian *belles lettres*, which and who determined its development from the 1890s till the late 1910s. Broadly studied are literature-history circumstances, peculiarities of the literature process of that period, the phenomena and figures that formed the contents of "Poetry" and "Prose" thematic units. Special attention is given to the creative individualities of Mykhailo Kotsiubynskyi, Olga Kobylianska, Vasyl Stefanyk, Marko Chermshyna, Les Martovych.

The volume presents the establishment of modernist artistic trends in Ukrainian literature, its stylistic variability and unanimity with the artistic pursuits of that time in the world of *belles lettres*, but at the same time, its national specificity generated by important spiritual pursuits of the Ukrainian culture and society in general.

The appropriate scholarly qualification of the book's authors, as well as its volume, corresponding to the problems addressed, have enabled the author's team to provide, with the reliance on current theoretical and methodological approaches (structuralism, myth criticism, psychoanalysis etc.), a radically new interpretation of numerous literature phenomena. It also shows the place of many now nearly forgotten poets and prose writers in the literature process. In particular, presented are such regional phenomena of all-Ukrainian importance as *Moloda muza* artistic group and Bukovyna prose at the turn of the century. Literature portraits of the leading prose writers of the period are presented from the viewpoint of current scholarly principles.

M. Bondar, O. Braiko (ed.), H. Burlaka, O. Kaminchuk, S. Kyryliuk, A.G. Matusiak, T. Meizerska, R. Pikhmanets, Y. Polishchuk, N. Shumylo (ed.)

Scanning electron microscopy studies of the fragments of cruise missiles and unmanned aviation platforms produced by the Russian Federation

S. P. Timoshenko Institute of Mechanics of the NAS of Ukraine, Technical Center of the NAS of Ukraine, in collaboration with the scientists of the Central Scientific Research Institute of Armaments and Military Equipment of the Armed Forces of Ukraine, analyzed physico-mechanical characteristics of the fragments of cruise missiles and loitering munitions.

Researchers investigated the chemical composition, structure and topography of the surfaces of composites used as materials for structural elements and coatings of cruise missiles produced in Russia, as well as materials for loitering munitions of *Shahed-136* type.

With the method of raster electron microscopy, they studied the microstructure characteristics of the solders used to manufacture electronic components of X-101 cruise missiles, 3M-14 missile of *Kalibr* complex, and anti-aircraft missile of C-300 complex.

Research was carried out into the physico-mechanical compositions of the materials of cruise-missile and aviation-missile fragments, in particular, of metal fragments of 3M14 *Kalibr* cruise missile engine, bodies of

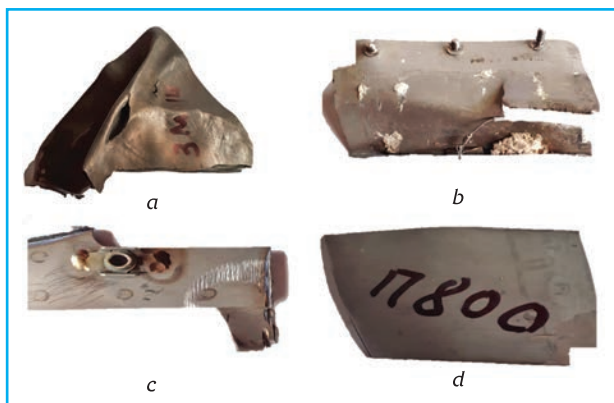

Fragments of cruise and aircraft-launch missiles produced by the aggressor country: a — metal fragments of 3M14 *Kalibr* cruise missile engine; b, c — fragments of P-37 and P-31 aircraft-launch missiles bodies; d — fragment of П-800 *Onyx* anti-ship missile

P-37, P-31 aircraft-launch missiles, and П-800 *Onyx* anti-ship missile.

To identify the countries of origin of unmanned attack aerial vehicles, microstructure characteristics of the airframe and civilian-purpose electronics that had been used in *Shahed-136* loitering munition were determined. They were proved to have been produced in the Islamic Republic of Iran.

The entire series of studies was carried out by scanning electron microscopy, employing X-ray JXA-8200 microanalyzer produced by JEOL Ltd (Japan) and JSM-6490LV scanning electron microscope with INKA Energy 350XT energy dispersion spectrometer.

These studies made it possible to obtain new information concerning technological solutions and assess the feasibility of developing similar materials and technologies for their future use by specialists of the enterprises of Ukrainian defense industrial complex.

V. Bogdanov, A. Grigorenko, V. Kremenytskyi, S. Sperkach

Modeling of light rays propagation through sensitive elements of fiberoptic sensors

A fast detection of the positions of enemy snipers who employ laser systems of target sighting or distance measuring, especially systems with the emission wavelength beyond visible spectrum, is one of the top-priorities of ensuring the survivability of combat units. An effective and simple scheme of danger alert and of determining the exact position of the enemy would significantly reduce the success of enemy's sniper systems and facilitate their neutralization.

Scientists of Pidstryhach Institute for Applied Problems of Mechanics and Mathematics of the NAS of Ukraine developed a relatively simple and inexpensive signal element in the form of diffraction lattice made of polyaniline fibers, which transforms the probe light beam from a dot spot into a diffraction band — a dispersed second-order curve whose shape depends on the light beam incidence angle in relation of the normal to the lattice. The curve type can determine the light source location in relation of the fiberoptic lattice.

In terms of their strength, elasticity and durability, textile materials with sensors that are easily integrated into them, in practice are not different from conventional ones. The optical fiber tissue unfolds the scanning laser beam from point (spatial dimension 0D) into a 1D strip for quasi-parallel fibers, or into a 2D light spot for the rectangular fiber net. The function of spatial distribution of dispersed light intensity provides information on the angle coordinates and distance of the light source emitting the probe beam.

Experimental studies showed that polyvinyl fibers are provided with the necessary mechanical characte-

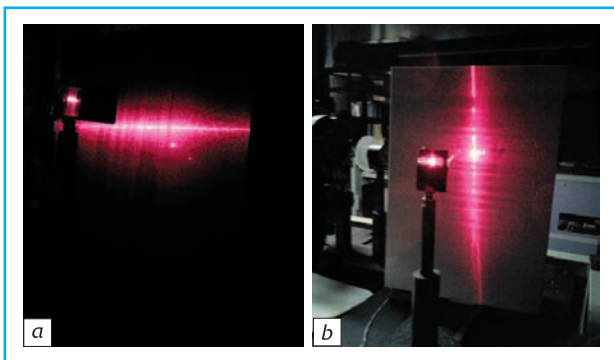
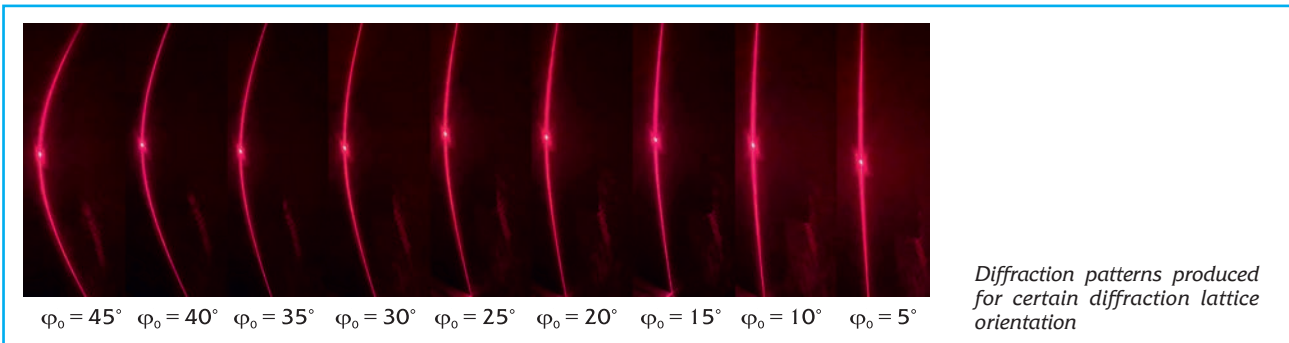

Laser light dissipation on a two-layer opto-fiber coil; orientation of fiber long axes: a – horizontal; b – vertical

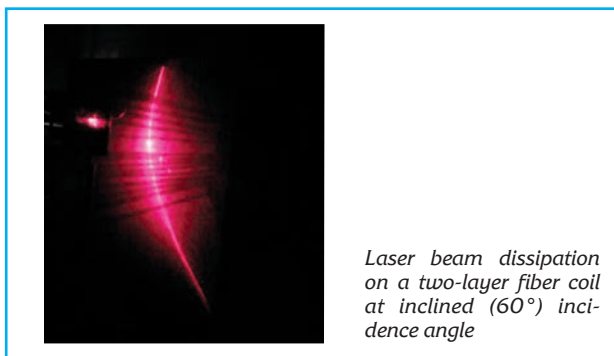

ristics: they can serve as the basis for optoelectronic sensors of the signals emitted by sniper sights. The effect of unfolding the dot cross-section into a linear band is based on light dispersion on threads of fabric as a result of diffraction on individual fibers, defocusing, and optic-fiber effect. So, the diffractogram is blurry.

The experimental results were approximated with the least-square method, and for an arbitrary diffraction lattice rotation angle, the coefficients of second-order values were determined.

Institute’s scientists developed a mathematical model describing the interaction of light rays with sensitive fiberoptic elements, and created respective numerical instruments, enabling any second-order curve to de-

termine in real time the diffraction lattice rotation angle or, in other words, the light source location respective of opto-fiber lattice. The results obtained and corresponding numerical instruments were transferred to Hetman Petro Sahaidachnyi National Army Academy to be used in developing means of artillery danger alert. The results of processing the signals emitted by sniper sight permit the analytical determination of the distance to a panoramic observer or a sniper by the power of the signal received, and their exact location — by the direction of received signals.

P. Vankevych, B. Drobenko

A complex for training and improving the skills of unmanned aerial vehicle operators

The International Research and Training Center for Information Technologies and Systems of the NAS of Ukraine and the MES of Ukraine set up a training center for pilot operators, which is certified within ‘The Army of Drones’ project of the digital transformation of Ukraine. This is an important step in developing unmanned aviation in Ukraine and it provides a high standard of training by taking into account current requirements to military pilot operators of UAV. The training of operators includes all aspects of driving, including the information on UAV theoretical aspects, simulator training and practical flight training. Operators pursue an intense course prepared by highly qualified instructors who have many-year experience in this sphere. Each aspect of preparation takes into account specific features of various unmanned aerial vehicles, their technical characteristics and requirements to driving.

To improve practical skills of UAV driving, instructors carry out training on advanced simulators developed by the International Center’s scientists. Those facilities reproduce realistic flight scenarios, the possibility of decision-making practice in real time. Each operator can pursue training in accordance with their proficiency level and needs: simulators allow adaptation of task difficulty and scenarios for each operator.



Training of FPV drone pilot operator

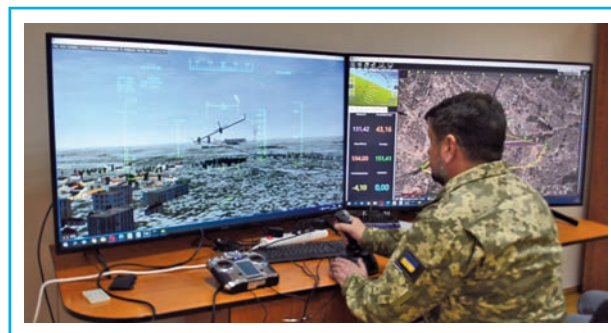

Training of pilot operator of aircraft-type UAV

The employment of systemic and complex approach to UAV operator training at the International Center ensures high competence of professionals ready to work with state-of-the-art technology of unmanned aviation. Highly qualified pilot operators who received training at the International Center are becoming an integral part of modern Armed Forces of Ukraine that is capable of employing advanced technologies in defending our state and its national interests.

O. Volkov, M. Komar, D. Volosheniuk

Ion-plasma processes of forming functionally stable coatings for improving artillery barrel performance

The most important characteristic of an artillery barrel is its service life, which determines efficient use parameters. The service life is limited mainly by the fracture of the gun bore functional coating under the action of periodic thermal shocks in the process of projectile exit, which is especially characteristic of the initial section of breech. The collective ion-plasma trampoline mechanism of modifying solid surfaces, which was discovered and investigated at the NAS Institute of Physics, allows the formation of a multi-layered functionally stable transitional structure between gun bore surface and the outer coating, which extends barrel service life.

An essential feature of realizing the trampoline mechanism of modifying a barrel bore, whose length is

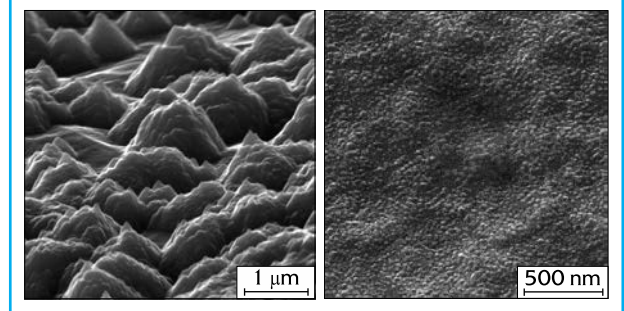

SEM microphotographs of the hierarchic submicron structure with nano-sized relief of the barrel bore surface (left) and of the dense surface after fabricating the film of nanocluster formations on the structured surface by trampoline sputtering of a target

larger than its diameter by several orders of magnitude, is the excitation of a non-self-sustained plasma glow discharge with improved parameters. A hierarchic submicron structure with nanosized surface relief in the 30-millimeter barrel bore is formed in trampoline mode regime. Altered electronic states in these nanoscale formations on the surfaces of submicron structures create conditions for strong adhesion and prevent functional film peeling caused by stress loads on the interface between the film and the bore due to the pressure of gunpowder gases.

When the coating film is produced due to the transfer of material in the form of nanoclusters as a result of trampoline sputtering of a multi-component target, with its composition preserved, the coating surface relief is levelled, and the sizes of surface nanostructures correspond to roughness Ra 0.025. Such roughness value is 15 times as low as that typical of bore surface. Respectively, this also reduces friction coefficient on it.

The investigation of film stability was carried out with a microprobe system for studying physico-mechanical properties of materials by dynamic scanning. The results of diamond-indenter scanning of chrome-nickel stainless steel film sputtered after previous submicron and nanosize structuring of the specimen surface show that under indenter pressure $17.5 \times 10^3 \text{ kg/cm}^2$ any signs of film peeling are absent. The characteristic pressure of gunpowder gases in the bore is $(3-3.5) \times 10^3 \text{ kg/cm}^2$, which is one fifth of the pressure applied in the studies.

The results of diamond-indenter scanning of the film sputtered without previous submicron and nanosized structuring of the specimen surface showed that the start of film peeling corresponds to the pressure about $3.5 \times 10^3 \text{ kg/cm}^2$. A total film failure occurs under indenter pressure $6.5 \times 10^3 \text{ kg/cm}^2$. The type of failure in the form of peeled macroscopic film fragments corresponds to those that are present in the bore under heavy heat loads due to intense artillery fire.

Thus, the possibility of employing the trampoline mechanism of modifying the internal surfaces of artil-

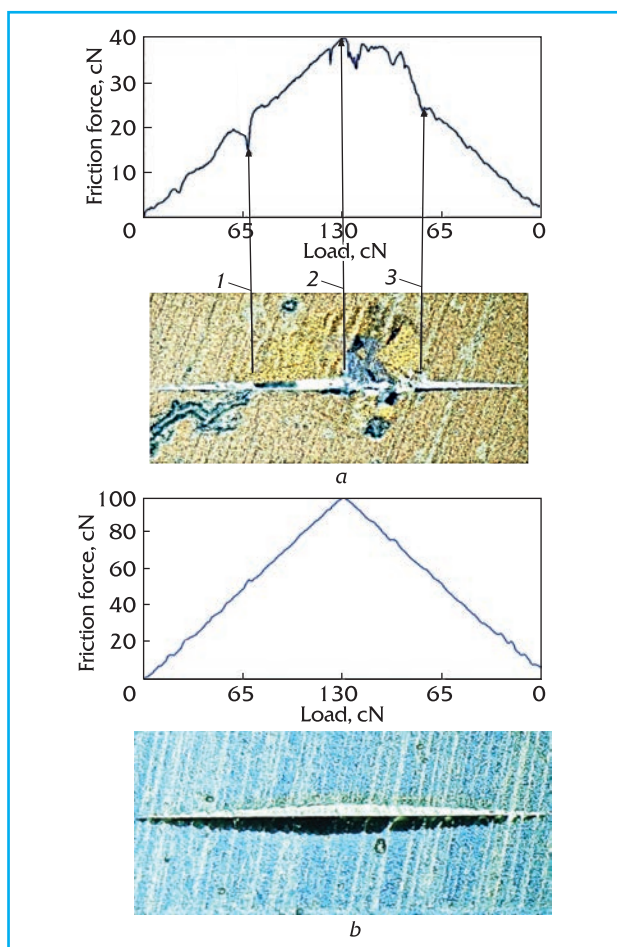

Results of diamond indenter scanning of the film sputtered without preliminary submicron- and nano-size surface structuring (a) and after it (b)

lery and small-arms barrels with bore diameters from 6 to 160 mm and barrel lengths up to 7000 mm for the 1.5—2-time extension of their service lives was proven experimentally.

O. Voitenko, O. Gabovych, M. Kruhlenko, O. Kurochkin, V. Nazarenko, V. Semeniuk, V. Styopkin

High-efficiency catalysts for producing cyclic carbonates from olefins

Scientists of L.V. Pisarzhevsky Institute of Physical Chemistry of the NAS of Ukraine developed highly effective catalysts based on hierarchical zeolites, as well as their composites, for one-reactor tandem process of olefins and CO_2 transformation into cyclic carbonates — monomers of biodegradable polymers, electrolytes of lithium batteries, precursors in organic synthesis, aprotic polar solvents etc.

The first stage of the process — olefin oxidation to the respective epoxide — is catalyzed by Lewis acid sites formed by titanium ions, or cerium cations of

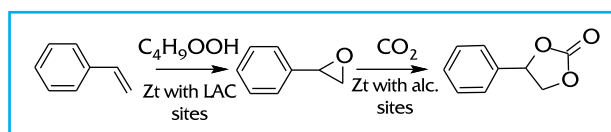

Scheme of the tandem reaction of styrene transformation into 4-phenyl-1,3-dioxolane-2-OH

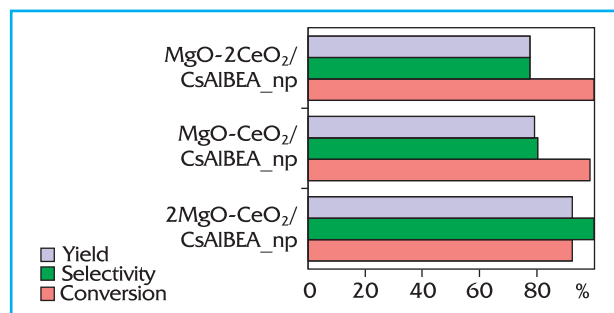

Catalytic characteristics of MgO-CeO₂/CsAlBEA nanocomposites, depending on Mg/Ce ratio

CeO₂ nanoparticles. The other stage of the process — formation of the respective cyclic carbonate — proceeds under CO_2 pressure with the involvement of zeolite alkali sites. High catalytic activity with target product yield up to 96.4% is demonstrated by titanium silicate zeolites of various structure types (BEA, MFI, MTW). An important prerequisite of high target product selectivity is the absence of Brønsted acid sites in catalysts.

It was found that the doping of CeO₂-based composites and zeolites with magnesium oxide in various concentrations allows a significant increase in both styrene conversion (up to 99.7%) and target product selectivity (up to 99%).

O. Shvets, M. Kurmach

Ultra-high-temperature ceramics with high creep resistance at operation temperatures up to 2100°C

Zirconium diboride takes the key place among ceramic materials and belongs to the class of ultra-high-temperature ceramics (UHTC). That became possible due to the unique combination of physico-mechanical properties, viz: high melting temperature, heat conductivity, low diffusion at elevated temperatures, and resistance to high-temperature oxidation.

One of important tasks on the way to producing UHTC based on zirconium diboride was to enhance or retain its mechanical characteristics since this class of ceramic materials is brittle, with crack resistance $\sim 2\text{--}3 \text{ MPa} \cdot \text{m}^{1/2}$. Adding 15—20 vol. % of silicon carbide (SiC) to the base proved effective since it allowed a 50—80% rise in mechanical characteristics of ZrB₂ and

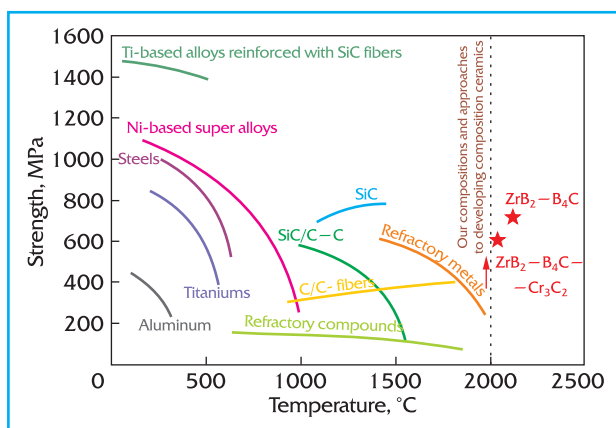

Temperature dependence of mechanical characteristics of composite materials as compared to ultra-high-temperature ceramics based on ZrB_2

its oxidation resistance to be several times higher as compared to single-phase zirconium diboride. This resulted in creating ZrB_2-SiC base composite. ZrB_2-MoSi_2 is another base composite having the highest oxidation resistance of all known composites based on zirconium diboride.

As discovered at I.M. Frantsevich Institute for Problems of Materials Science, the rise in testing temperature produces a negative effect on the mechanical characteristics of base composites. ZrB_2-SiC composite was found to have a high creep rate at 1800 °C. Such behavior is caused by the formation of $Zr(B,C)_2$ submicron grains of 0.05–0.25 μm size during testing, which accelerates creep processes at low temperatures. The formation of Mo solid solutions in ZrB_2-MoSi_2 ceramics retards creep and shifts it towards elevated temperatures (up to 1900°C). This takes place due to solid solutions formed on ZrB_2 boundaries of $(Zr, Mo)B_2$ composition, as well as the presence of MoB rigid phases in them, which play the role of the strengthening phase.

Since the abovementioned class of materials was to work at temperatures above 2000 °C, it was necessary to develop the composition of ultra-high-temperature ceramics, along with the technologies of its production, which would be able to operate at such high temperatures and retain high mechanical properties, first of all, creep resistance.

One of the solutions was the substitution of silicon-containing additives ($SiC, MoSi_2$) for those forming rigid phases with the uniform distribution over the microstructure during interaction. Such additives are carbides, primarily, boron carbide (B_4C) and chromium carbide (Cr_3C_2). Technologically, the CO atmosphere forming during hot pressing is an additional carbon source that emerges in $CO \leftrightarrow C + CO_2(g)$ reaction. This allows uniform distribution of the reducing agent over the entire bulk of the material which is under consolidation.

In the phase composition of the ceramics developed, there are no low-melting components and oxide grain-boundary interlayers, which made it possible to produce within $ZrB_2-B_4C-Cr_3C_2$ a structure in which the formation of $Zr(B,C)_2$ solid solutions of 1–2 μm size provides high creep resistance at testing temperatures 2000–2100 °C.

Thus, Institute's scientists were the first in the world to develop the composition and production technologies of ultra-high-temperature ceramics having high creep resistance at operation temperatures up to 2100°C. The development was carried out in accordance with the tasks posed by the SE "M.K. Yangel Pivdenne Design Office" (Dnipro) and will be used for structural units of novel rocket technologies.

O. Grigoriev, V. Vinokurov, T. Mosina, L. Klymenko

A technology of producing neutron-absorbent materials and the structure of absorbing rods for control and protection systems

As of today, the diversification of nuclear fuel for water-water energy reactors (WWER-1000) is of utmost importance and complexity. An integral part of nuclear fuel are neutron-absorbent materials and the elements of reactor control and protection that are based on them and are a kind of reactor's steer. The main elements of WWER-1000 reactor control and protection are absorbing rods of the control and protection system (further AR CPS). Until now, no one except the Russian Federation developed and produced AR CPS for WWER-1000 reactors. To procure AR CPS for Ukrainian WWER-1000 reactors after the beginning of the full-scale Russian aggression became impossible.

National Science Center 'Kharkiv Institute for Physics and Technology' (NSC KIPT) has accumulated an extensive experience in developing absorbing element structures, with various materials used, including complex compounds of gadolinium monoaluminate, boron carbide, metallic hafnium etc. S&T Complex 'Nuclear Fuel Cycle' (STC NFC) of this center carries out materials-science and technology research to substantiate the development of absorbing rod structures. The draft design of absorbing elements (AEL) and AR CPS for WWER-1000 of Ukrainian NPPs was completed. The technology of producing neutron-absorbent materials, the structures of absorbing elements and rods were developed. Technical specifications for AR CPS were formalized and agreed with *Derzhatomregulivannia* agency. Procedures for checking element composition of oxides, phase composition of dysprosium titanate by mass spectrometry with inductively bound plasma were developed and certified at *Analytstandartmetrology* S&T Center Ltd.

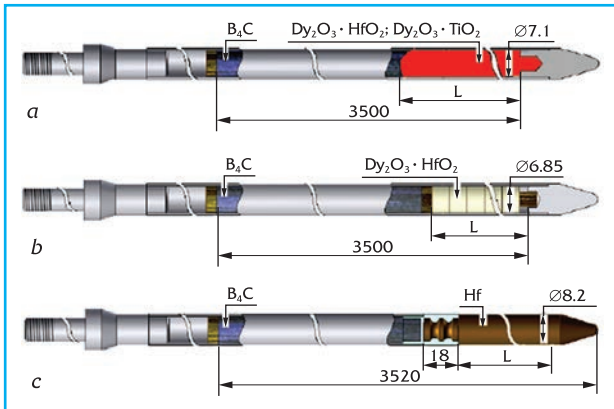

Structure of AEL of AR CPS of WWER-1000 reactor: a — versions I, II, III with powdered absorbents; b — version IV, in which γ absorber is in tablet form; c — version V, with hafnium rod of $\varnothing 8.2$ mm (patents of Ukraine № 69082, 76216, 98429, 104325)

Quality characteristic of dysprosium titanate powder	Value, %
Dysprosium mass part, %	— 72
Titanium mass part, %	— 13
Mass part of particles smaller than 900 μm	95
Mass part of particles smaller than 100 μm	not more than 50

Phase structure composition of the material: base — Dy_2TiO_5 with fluorite or pyrochlore structure; the presence of others modifications of dysprosium titanate, as well as TiO_2 traces is admissible

To organize manufacturing of enlarged lots of the abovementioned products at STC KIPT at implementation stages, a specialized production facility was set up, which is provided with laboratory equipment for producing neutron-absorbent materials of absorbing elements and rods. At the order of 'NAEC Energoatom' Corporation, the newly-organized facility fabricated in accordance with the developed technological operations an enlarged pilot lot of 12 AR CPS to be tested in WWER-1000. The Program and Technical Solution on mounting and experimental exploitation of AR CPS at power unit № 4 of Rivnenska NPP were developed; they were approved by 'NAEC Energoatom' Corporation.

The supply of a AR CPS pilot lot to reactor testing was scheduled for fuel reload at Unit 4 of Rivnenska NPP in March 2024.

V. Krasnorutskyy, V. Grytsyna, I. Chernov, V. Zigunov, V. Zuyok, A. Kushtym, V. Grudnytskyi

High-efficiency steam turbine with ultra-supercritical steam parameters of power units at Ukrainian heat power plants

Scientists of A. Podgorny Institute of Mechanical Engineering Problems of the NAS of Ukraine conducted

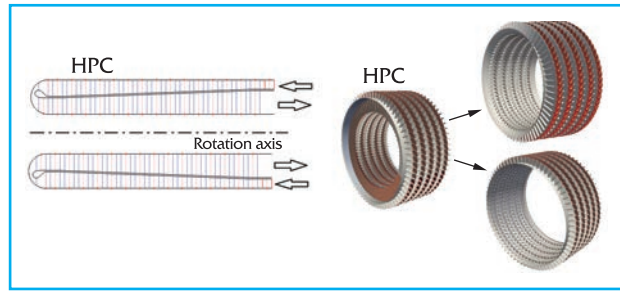

Longitudinal meridional section of the new HPC and isometry of additional MPC stages

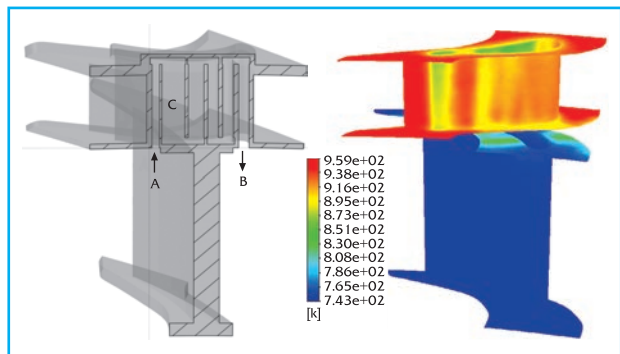

Configuration of cooling channels and temperature distribution on the surfaces of the blades of the first and last stages

research into increasing the efficiency of steam-turbine installations by operating them at ultra-supercritical initial parameters (pressure > 32 MPa and steam temperature > 630 °C) and proposed a solution unique for gas and steam turbines — the loop scheme of the structure, which had never been used in turbine power units.

The use of loop scheme with two-layer blades makes it possible to solve a number of design and technological problems, viz.: to reduce axial dimensions of the turbine, compensate axial loads and cool the blades with energy saving in the operation mode. To switch to ultra-supercritical parameters for inducing a larger thermal difference in the turbine, a new high-pressure cylinder (HPC) was developed and additional stages at the beginning of medium-pressure cylinder (MPC) were introduced. Because of high temperature in the first stages, internal cooling of the blades is realized, which is implemented by colder steam withdrawal from the "lower" parts of blades. When 2% of steam mass is spent for cooling, the average temperature on the blade surface drops by 62.2 °C in HPC and by 40.4 °C in MPC.

Turbine flow parts were developed by means of IPMFlow software produced at A. Podgorny Institute of Mechanical Engineering Problems of the NAS of Ukraine; its advantage is the possibility of effective parallel computations.

Flow parts geometry was determined, their strength was calculated and materials for them were chosen.

Due to the cooling system proposed, the possibility of using a relatively inexpensive material was proved, which will ensure high competitiveness of the turbine.

Numerical studies proved high internal efficiency of new flow parts of HPC and MPC, which amounted to 94.18% and 94.5%, respectively. That provided a rise in the plant power by 80.64 MW and permitted its thermal efficiency to be increased to 49.2%, which exceeds the respective characteristics of the best K-300 turbines by more than 5%.

The development work was carried out in collaboration with specialists of *Ukrainian Energy Machines* company. It is planned to be implemented during updating and renewal of power units at Ukrainian heat-and-power plants, which will increase turbines efficiency and reduce the specific consumption of standard fuel.

R. Rusanov, K. Dehtiarov, I. Palkov, S. Palkov, D. Kriutchenko

Nanocomposite materials and technologies for manufacturing products with bactericidal activity

Infectious diseases caused by viruses and pathogenic microorganisms still remain a major problem for health protection in the whole world despite the rapid progress in developing medicines and advancing pharmaceutical technologies. The risk of complications and rapid spreading of diseases is high, which was very strongly manifested during COVID-19 pandemic. To deal with this challenge, a lot of attention is given to nanocomposite materials, as it is well-known that antiviral and antimicrobial effects of materials which are in contact with the environment is related to the size of their components — in particular, with the reduction in the size of nanoparticles their bactericidal efficacy rises dramatically.

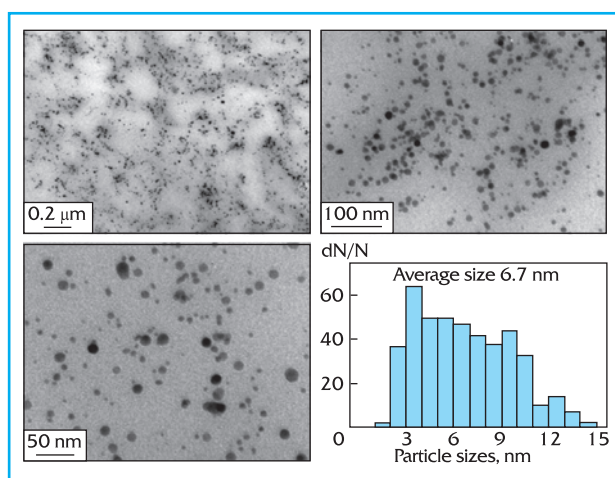

Electron microscopy images and histogram of silver nanoparticles distribution in the biopolymer nanocomposite produced by thermochemical reduction of Ag^+ ions

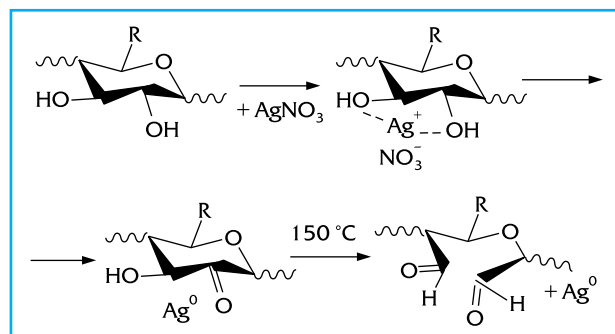

Mechanism of thermochemical reduction of Ag^+ ions in biopolymer nanocomposite

Scientists of E.O. Paton Electric Welding Institute of the NAS of Ukraine, by employing the electron-beam method of physical deposition in vacuum, synthesized biologically pure (ligand-free) copper nanoparticles in the porous matrix of sodium chloride (NaCl). They investigated the structure, element composition, phase content and size of nanoparticles, as well as their thermal stability in $\text{NaCl}-\text{Cu}-\text{O}$ system. It was shown that nanoparticle dimensions and phase content can be controlled by both synthesis and heat treatment of the condensate. High sorption capacity of small-sized copper nanoparticles in respect of oxygen was revealed. Control of the activity (size) of copper particles by regulating copper content in the condensate, synthesis temperature, and annealing time will enable specialists to produce various copper-based nanomaterials with the set content of necessary structural components (Cu , Cu_2O , CuO).

Biopolymer nanocomposites based on polylactide with silver nanoparticles were produced. Nanocomposite formation was carried out in three ways: reduction of silver ions in a polymer matrix by employing "green" chemistry methods, mechanically introducing separately synthesized silver nanoparticles into a polymer matrix, and by sputtering silver nanoparticles onto polymer surface. On their basis, using extrusion method, filaments were produced and by means of FDM 3D printing products were fabricated of them. It was shown that when polyethyleneimine was used as the reducing and stabilizing agent, silver nanoparticles of the average size 6.7 nm were formed but when strong electrolyte chitosan was employed, particles of the average size 4.2 nm were formed. It was found that products fabricated with the technology of FDM 3D printing at $T = 160^\circ\text{C}$ contain silver nanoparticles whose morphology is similar to the morphology of nanoparticles in the synthesized source materials, which proves the feasibility of forming bioactive products in a single stage — directly during FDM 3D printing. It was demonstrated that in film materials into which separately synthesized silver nanoparticles were introduced their

sizes are in the range of 30–40 nm, while in the synthesis of nanoparticles by the reduction of Ag^+ ions in a polylactide polymer matrix (*in situ*) their sizes are in the range of 5–10 nm. When products are formed by employing the technology of FDM 3D printing, silver nanoparticles tend to aggregate. Relying on electron microscopy method, researchers revealed that when silver nanoparticles are sputtered onto polylactide surface, their sizes are in a wide range of 8–40 nm. The antimicrobial and antiviral action of the studied materials and products made of them was proved for gram-positive reference strains of conditionally pathogenic microorganisms *Staphylococcus aureus*, gram-negative — *Escherichia coli*, *Pseudomonas aeruginosa*, yeast-like fungi *Candida albicans*, herpes, flu viruses and adenovirus. In all studied materials, cytotoxic (mutagenic) effect was not detected at the co-cultivation of peripheral blood lymphocytes and silver-containing nanocomposite materials.

M. Iurzenko, V. Demchenko, Yu. Kurapov, S. Lytvyn

Heat-resistant polymer composites based on domestically produced bisphthalonitrile as a fiberglass binder

Research scientists of the Institute of Macromolecular Chemistry of the NAS of Ukraine developed a heat-resistant composite based on domestically produced bisphthalonitrile as a binder for fiberglass with high performance at elevated temperatures. Experimental specimens of the fiberglass binder were checked in experimental laboratory at ANTONOV State Enterprise.

The binder developed has elevated vitrification temperature, the temperature of the start of intense mass loss in the air, elasticity modulus above 150 and 200 °C. With that, the binder retains 97–98% of the initial elasticity modulus at 150 °C and 45–50% at 200 °C. Hence, the use of the developed binder will enable engineers to raise the reliability and extend the operation life of the products of aviation-and-space, ship-building industries, and of other industrial branches.

As compared to the best domestic counterparts, the fiberglass produced on the basis of the binder developed has higher values of tensile, bending, and

Fiberglass key properties

Binding plastic content		21,2 mass %
High strength characteristics:		
tensile strength	$T = 23\text{ °C}$	51,9 kgs/mm ²
	$T = 180\text{ °C}$	49,0 kgs/mm ²
compressive strength	$T = 23\text{ °C}$	34,5 kgs/mm ²
	$T = 180\text{ °C}$	23,9 kgs/mm ²
bending strength	$T = 23\text{ °C}$	64,5 kgs/mm ²
	$T = 180\text{ °C}$	—

compressive strength at temperatures 180 °C and above, which makes possible its use in manufacturing structures operating in high-temperature zones. These characteristics are at par with their best foreign counterparts.

The material proposed is a novelty, which is proved by the patent of Ukraine for invention, and is promising for use in aviation structural units.

A. Fainleib

Water-resistant biocides for antifouling paints

V.P. Kukhar Institute of Bioorganic Chemistry and Petrochemistry of the NAS of Ukraine synthesized novel hydrophobic ionic liquids that are promising biocides — substances for antifouling ship paints. The compounds produced are highly soluble in paint and varnish solvents, which permits them to be introduced directly to commercial lacquers and paints with the following homogenous distribution in protective coatings. Hydrophobic liquids produce plasticizing effect on polymer coatings of various structures (chlorovinyl, epoxy, alkyd ones), increase their elasticity and provide high adhesive characteristics. Contrary to traditional antifouling substances based on tin and copper compounds, hydrophobic ionic liquids are not released into the aqueous media from protective polymer coatings and, respectively, do not produce negative effect on the environment.

During collaborative research with the NAS Institute of Hydrobiology, full-scale tests were carried out concerning the resistance of protective coatings based on ship paints produced in Ukraine (ПФ-167, XC-413) modified with new biocide components against biofouling. After 5–6-month exposure of polymer coating specimens on the stationary testing facility in fresh water (the Dnieper River), the surfaces of coatings containing 10–20% of hydrophobic ionic liquids had a two orders of magnitude smaller amount of attached biomass as compared to control samples. These synthesized biocides can be used for developing new en-

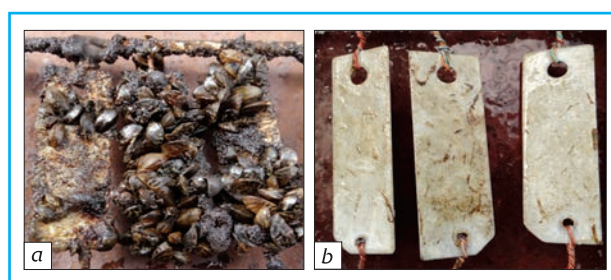

Samples of steel plates coated with ПФ-167 alkyd enamel: a — pure paint; b — paint with added hydrophobic ionic liquid (20%) after 5-month exposure in the Dnieper River

vironment-friendly protective coatings for underwater structures with high anti-fouling resistance.

S. Rogalsky, O. Dzhuzha, O. Tarasyuk

Treatment of panresistant hospital infections caused by klebsiella

Scientists of the NAS Institute of Molecular Biology and Genetics developed a combined therapy of *Klebsiella pneumoniae* — associated nosocomial infections. This therapy uses antibiotics available in Ukraine and is effective in respect of panresistant hospital strains of this pathogen. It is important that the therapy proposed is affordable in terms of cost and is a combination of two classical antibiotics that are widely available on the home market.

The studies of Azithromycin antibiotic effect on the abovementioned strains, as well as nonresistant and standard strains showed that despite the klebsiella in-born phenotypic resistance to macrolides, all *K. pneumoniae* strains demonstrated sensitivity to Azithromycin both in the plankton form and as a biofilm. At the same time, it was shown that Colistin drug does not have any antibacterial action against plankton klebsiella subpopulation but has some antibiofilm effect which is considerably increased in the presence of Azithromycin — i.e., the antibiotics demonstrated synergy.

An *in vitro* model of wound infection was created, and test results demonstrated that Colistin was almost ineffective on the Colistin-sensitive klebsiella culture, while Azithromycin significantly reduced biofilm for-

mation and suppressed klebsiella plankton population in the model. Besides, it was found that Azithromycin affects klebsiella biofilm structure, in particular, it suppresses the formation of matrix amyloid fibrils, while Colistin does not prevent the synthesis of bacterial functional amyloids.

Relying on the results of research conducted, Azithromycin was successfully used in treatment of the infections caused by panresistant hospital strains of *K. pneumoniae* as a part of combined therapy of severe infections of the military.

O. Moshynets, Ya. Poholenko

EU Action Plan for protection and conservation of endangered wild pollinator bees

State Institution “The Institute for Evolutionary Ecology” of the NAS of Ukraine, in collaboration with European partners, developed an EU Action Plan concerning protection and conservation of the most endangered wild pollinator bees. This plan relies on many years of basic research into peculiarities of the biology and ecology of wild bees. Besides, measures towards protection and conservation of the most vulnerable species of wild pollinator bees were proposed, since new nature-protection legislation of the European Union gives the first place to the issue of plant pollinator conservation under negative anthropogenic impact. Such focus on this insect group results from the threatening assessment data obtained with extensive participation of NAS scientists in preparing the first European Red List of Bees, which showed that every tenth species of wild bees in Europe is endangered and this, in turn, can lead to the extinction of numerous flower plants and essential degradation of terrestrial ecosystems.

The action plan concerning the protection and preservation of wild pollinator bees for 2023—2030 was issued by the Publications Office of the EU with the support of the European Commission Directorate-Ge-

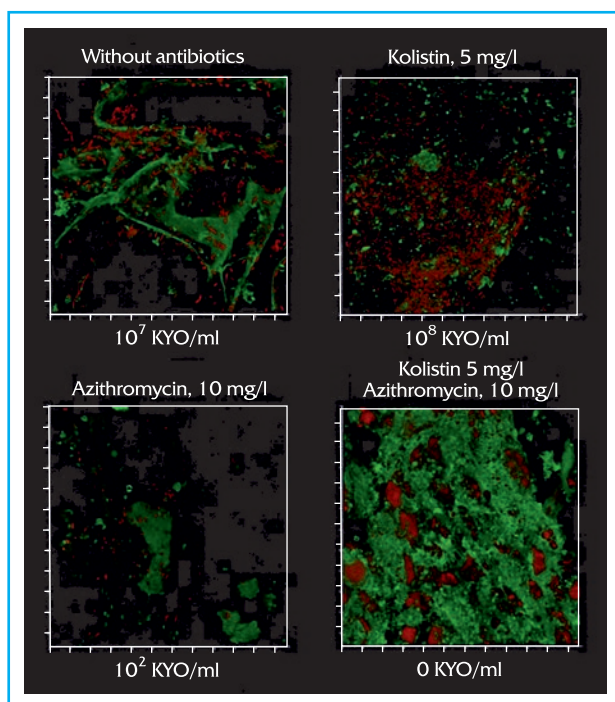

24 Efficacy of the chosen antibiotics for polyresistant klebsiella infection in the wound surface model



neral for Environment and the European Regional Office of the International Union for Conservation of Nature (IUCN) as an official edition and it was placed on the European Union website for further use by all EU member states.

V. Radchenko

An alternative scenario of the Kakhovka Reservoir restoration

Scientists of the Institute of Hydrobiology of the NAS of Ukraine developed scenarios of water balance and dynamics of the natural flow of the Lower Dnieper after Russian troops blew up Kakhovka Hydro Power Plant. Their computations showed that in July — August, and sometimes in October as well (with the exception of wet years), the natural flow of the Dnieper is less than 500 m³/s, i.e. it is lower than the minimal ecological flow necessary for the stable existence of hydro-ecosystems in the lower Dnieper, in its delta and in the Dnieper — Bug estuary. With such volumes, there are degradation, rotting of floodplain lakes, island bays, the death of straights and Dnieper distributaries, as well as its delta. The lack of water for ecological flow, which was provided by water releases from the Kakhovka Reservoir also causes the problem of advancing salty water wedge from the estuary into the Dnieper channel.

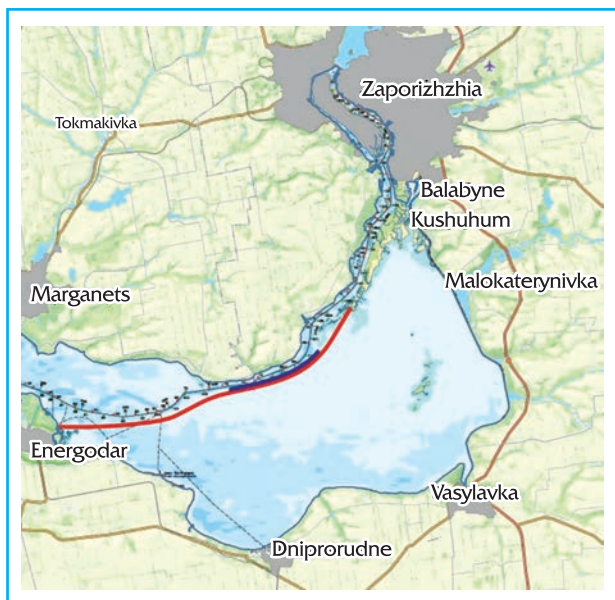

Scheme of damming the shallow part of Kakhovka Reservoir with the purpose of creating quasi-natural meadow ecosystems on the place of Velykyi Luh

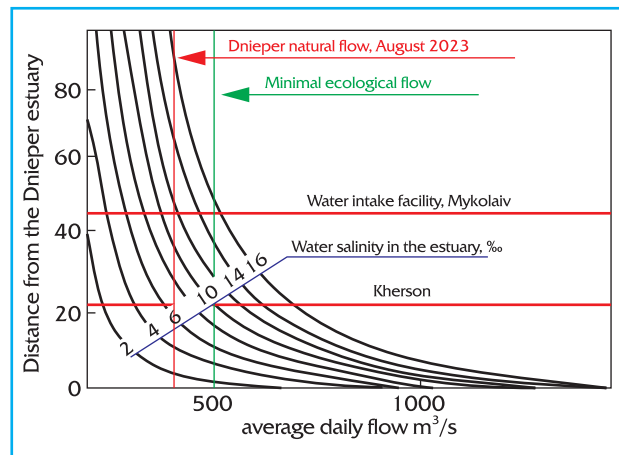

Nomogram for determining the length of salty water edge in the mouth part of the Dnieper at various parameters of the river water content and water salinity in the Dnieper — Bug estuary

Understanding the necessity of restoring the Kakhovka Reservoir as a source of water for various industries, power plants, agriculture, for water supply to the region inhabitants, as well as for ensuring sustainable ecological flow, NAS Institute of Hydrobiology proposes to erect a dam in the north-east shallow part of the reservoir, which once was the territory of sacred Velykyi Luh. This most shallow, rich in lakes part occupied over 33% of the total reservoir area, but it held about 18% of its volume, only one third of which was involved in active regulation of the flow. It was the place where blue-green algae thrived most extensively, causing water bloom, and where massive fish kill was observed.

The protective dam is to be about 40-kilometer long. The reduction of reservoir area would lead to increased river flow, which will be favorable for artificial spawning grounds and the arrangement of biopositive structures. The length of the protective dam part suitable for artificial spawning grounds for sturgeon fish will be about 12 km. At the same time, it is required to create an effective fishway for sturgeon and other migratory fish species. It is also necessary to build pump facilities for pumping over the Konka (Kinska) River flow and drainage waters that will filter through the dam to the Dnieper.

The return of Velykyi Luh as a floodplain ecosystem is unlikely, since there will be no natural floods and arrival of flow sediments, yet, quasi-natural meadow ecosystems like those that can be seen in Osokorky near Kyiv can be easily created here. In any case, these lands, after appropriate recultivation, can be used for other economic needs as well.

S. Afanasyev, S. Dubnyak

INTERNATIONAL COOPERATION UNDER CURRENT CHALLENGES

In 2023, the slogan **"UKRAINE TENIR!"** was added to the 2022 international slogan **"STAND WITH UKRAINE"**.

Since the beginning of the war the international scientific community, together with the whole world, has adequately assessed the Russian aggression against Ukraine, stopped cooperation with numerous Russian and Belorussian scientific organizations and provided comprehensive support to science in Ukraine.

On 28 March, a meeting of NAS leadership and scientists with the delegations of the Polish Academy of Sciences (PAS), US National Academy of Sciences and the Center for Science Diplomacy of the US Association for the Advancement of Science was held. It discussed the current issues and prospects of cooperation



in conditions of the Russian war against Ukraine, in particular, those concerning the defense capability of this country, health protection system, inclusive development of national scientific institutions, and its potential in generating adequate responses to new challenges in the context of national priorities.

On 29 June 2023, Warsaw hosted another meeting of the high-level coordinating group for the support and development of Ukrainian science, which was attended by the presidents of the PAS, the US National Academy of Sciences, the Royal Danish Academy, the NAS of Ukraine, authorized representatives of the Royal Society of Great Britain, the Australian Academy of Sciences, the Royal Swedish Academy of History, Literature and Antiquities, the National Academy of Sciences of Germany *Leopoldina*. Participants of the meeting discussed urgent matters of the development of Ukraine's science sphere, the status of implementing the Action Plan to support Ukrainian science. The results of the contest for supporting Ukrainian research groups, which had been organized by the PAS jointly with the US National Academy of Sciences, were announced. Of the applications submitted, 18 winning projects were chosen, 11 of those were presented by NAS institutions. All research teams are headed by leading scientists who will work at one of the PAS institutions, while research group members can carry out their tasks in Ukraine, having a dual affiliation — with a Ukrainian scientific institution and a PAS institute.

Important milestones in the development of cooperation between Ukrainian and German scientists were the participation of a NAS delegation in the events on the occasion of the 30th anniversary of German — Ukrainian S&T cooperation held in Berlin and in the work of the 14th meeting of the German — Ukrainian work group for collaboration in science and technology, which discussed specific initiatives concerning S&T cooperation, in particular, the activities of German — Ukrainian centers for advanced scientific research in Ukraine, or *Cores of Excellence*. The winners of four joint



Special events on the occasion of the 30th anniversary of German Ukrainian S&T cooperation (Berlin, Germany) with the participation of Academy leadership

projects for organizing German — Ukrainian advanced research centers were announced, two of those — with the involvement of NAS institutions: the Center for Advanced Quantum Materials Research *GU-QuMat*, which will work on search for novel quantum materials for developing future technologies, and the Center for Advanced Research of Plasma Technologies *PLASMA-SPIN-ENERGY*, which will deal with plasma technologies employed in producing spintronic components which, in particular, are the basis for computers of the next generation. The centers will function thanks to funding from the German side and will be headed by leading Ukrainian and German scientists.

On 15 November 2023, the Academy was visited by a delegation of the French National Centre for Scientific Research and Collaboration *LHCb* of the European Organization for Nuclear Research (*CERN*). During the meeting, a *CERN* representative conveyed greetings and words of support for the Academy and the entire Ukrainian people from the *CERN* leadership. He emphasized that one of the most important purposes of his visit was the search for ways and means of expanding mutually beneficial cooperation.

In October 2023, Ukraine acquired the status of observer in international research infrastructure project — *The International Fusion Materials Irradiation Facility, Demo Oriented Neutron Source (IFMIF-DONES)*, aimed at the development and exploitation of a new source of fusion neutrons. Due to that, a representative of Ukraine, an expert from the NSC 'Kharkiv Institute of Physics and Technology', together with representatives of 17 member states and the European Commission, as well as the consortium of European fusion laboratories *EUROfusion* and *Fusion for Energy*, took part in the meeting of the *DONES* Second Steering Committee.

Despite war-time limitations, Academy research teams gave a lot of efforts to presenting Ukrainian science at various international forums. In particular, R.E. Kavetsky Institute of Experimental Pathology, Oncology and Radiobiology of the NAS of Ukraine represented Ukraine at the 45th session of the General Assembly of European Cancer Institutes (*OECI*) in Paris. François Braun, France Minister of Health, addressed the session with the words of comprehensive support to Ukraine on its way to the European Union. An important event of the 45th *OECI* General Assembly was a plenary meeting concerned with upgrading Ukraine's oncology service. All activities in the framework of the General Assembly were conducted under the flag of Ukraine. The decision of the General Assembly to allocate a grant in support of the military who were wounded during Russian military aggression against Ukraine deserves special attention and thanks.

Successful implementation of 27 projects in the framework of 'Horizon Europe' program was going on;



Visit of the representatives of the French National Centre for Scientific Research and LHCb Collaboration of the European Organization for Nuclear Research to Ukraine

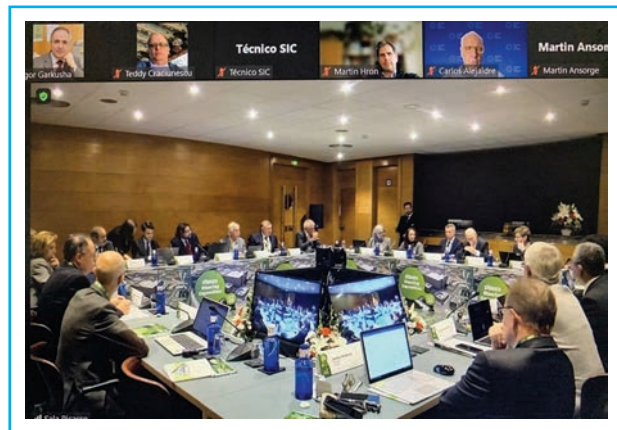

Meeting of the DONES Steering Committee with the participation of Ukraine

seven of those were carried out under the research and training program of the European Atomic Energy Community (*Euratom*). In particular, the NAS Institute for Scintillation Materials, in cooperation with colleagues from *CERN* (Switzerland) and the National Center for Nuclear Research (France), in January 2023 started *TWISMA* 3-year project under 'Horizon Europe' program. Its aim is to produce and test at *CERN* a prototype of calorimeter based on crystalline materials developed at the Institute in high-energy experiments for precise measurement of particle energy.

The implementation of 15 projects carried out under NATO Program 'Science for Peace and Security' resulted in developing important defense products: ultra-wideband pulse georadar (a laboratory model) for remote mine detection, laminated titanium structures with high protection properties, which are to be used as armor elements, prototypes of quantum sensor devices for express analyses of chemical, biological, radiological, nuclear substances in complex gaseous and liquid environments etc.



NAS representatives at the 45th session of the General Assembly of Cancer Institutions of Europe (OECE) in Paris

The international support of Ukrainian science remained to be of utmost importance for the Academy. New competitions for grants for Ukrainian scientists were announced and support programs were started. E.g., the office of the US Civilian Research and Development Foundation announced a competition for grants in support of scientists, technical specialists and engineers specializing in chemical, biological, radiation and nuclear safety; the American Physical Society announced two new support programs for physicists and physics students; the US National Science Foundation, jointly with national science foundations of five European countries, declared a new initiative 'International Multilateral Partnership for a Resilient Science and Education System in Ukraine'; extra grant opportunities were provided by the Netherlands Research Council; the Australian Academy of Sciences, in the partnership with *Breakthrough Prize* Foundation, implemented yet another round of the program in support of Ukrainian researchers; in the framework of the *EURIZON* project, a program was opened in support to the sensitive groups of scholars of all science branches in Ukraine; *Nanophotonics* journal, in cooperation with *Optica Foundation*, announced a grant program in support of Ukrainian researchers and academics; Berlin Science College (*Wissenschaftscolleg zu Berlin*), in close

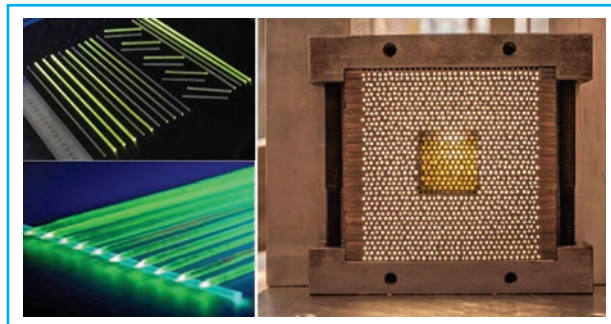

Scintillation fibers developed by Academy scientists and the prototype of calorimeter for experiments at CERN

cooperation with partner institutes in Ukraine, Europe and the USA, launched the initiative for supporting Ukrainian scientists 'Virtual Ukrainian Institute for Advanced Research' (VUIAS).

In the year under review, the donation of advanced scientific equipment as a humanitarian aid from leading world producer companies was a significant contribution to updating Academy's research infrastructure. Of the 15 instruments planned in 2022 by four companies, as of the end of 2023, 14 were delivered. Academy institutions received an atomic-absorption spectrometer, three spectrophotometers from *Analytic Jena* company; an IR Fourier spectrometer from *Bruker Corporation*; six optical and light microscopes of various profiles from *Carl Zeiss* company; gas and liquid chromatographers, a fluorescent detector from the company *Agilent Technologies Inc.*

A certain sign that Ukraine is retaining its high positions in the international scientific area was publicizing in May 2023 the **Global 2000 rating** by the *Center for World University Rankings*. The list of two thousand institutions, chosen from 20 thousand, included six Ukrainian institutes, five of which are research institutes of the National Academy of Sciences of Ukraine: the Institute of Mathematics, the NSC 'Kharkiv Institute of Physics and Technology', the Institute for Nuclear Research; Glushkov Institute of Cybernetics, the Institute for Scintillation Materials.

VOLUNTEER MOVEMENT AT THE ACADEMY

Since the very beginning of the full-scale Russian aggression, employees of Academy institutions actively joined volunteer and charity work.

Associates of Pidstryhach Institute for Applied Problems of Mechanics and Mathematics personally transferred ₾120,000 to support the military and their families and organized fundraising from all caring citizens, due to which ₾2 million was accumulated and transferred to 'Return Alive' foundation for procurement of Quadro copters, occlusion bandages, tactical equipment etc.

The volunteer group led by Oleh Klymenkov, scientist of the Institute of Telecommunications and Global Information Space, regularly supplies means of communication, *Mavic* Quadro copters, *FPV* drones, night vision devices etc. to the frontline.

Employees of S.P. Timoshenko Institute of Mechanics in the NGO 'Volunteer Movement Battalion Net' are sewing textile products for the military at the front and clothes for the wounded.

Research associates of the Institute of Technical Mechanics work actively in 'Oberih' and 'Elsa Descendants' volunteer centers, are engaged in weaving camouflage nets and "kikimoras", collecting tissues and sewing underwear, headwear, mattresses to be sent to the frontline and military hospitals.

Kyrylo Savchenko, scientist of G.S. Pysarenko Institute for Strength Problems, is a co-founder and head of 'Wings of Justice' charitable foundation. It handed winter clothes, thermal underwear, sleeping bags, burners and gas cylinders for them, "bourzhuika" (potbelly) stoves, gasoline and diesel generators, charging stations, tablet computers and laptops to the military who are in the war zone, along with a full-drive car purchased by our compatriots abroad. The foundation established cooperation with a Ukrainian producer of energy drinks to send them to the military.

The Institute of Transport Systems and Technologies collaborated actively with *Drones&Dudes* volunteer community, Serhii Prytula's and 'Return Alive' foundations.

'Physicists-Lyricists' volunteer group was set up at M.M. Bogoliubov Institute for Theoretical Physics back in 2014. Volunteers developed a unique technology that allows fast and inexpensive production of high-

quality camouflage nets in large numbers. Besides, they accumulate clothes, food products, essentials and bring those to the front.

Anton Senenko, scientist of the Institute of Physics, is engaged in fundraising and purchasing automobiles for the military. The volunteer called this project '42 "tachkas" for the Armed Forces of Ukraine' — he is planning to send this number of cars to the frontline.

Associates of V.Ye. Lashkariov Institute of Semiconductor Physics, Bohdan Kulchytskyi and Victor Strelchuk in particular, are involved in the volunteer organization whose work is focused on providing support to the servicemen of the 45th brigade of the 59th howitzer division of the Armed Forces.

Olena Kompaniyets and Serghii Pokhvala, researchers of the Main Astronomical Observatory, are proactive in their charity and volunteer work at 'Wings of Victory' NGO.

Scientists of the Institute of Electron Physics collaborate with charitable organization *PUMA* (Plymouth Ukraine Medical Aid — Plymouth, England). Victoria Roman is its main coordinator in Ukraine and Yurii Azhniuk serves as interpreter. During the full-scale war, this organization paid 11 visits to Ukraine, providing humanitarian aid to this country. In 2023 they donated ambulances for the Armed Forces, medicines for hospitals, humanitarian aid for internally displaced persons, elderly people homes and orphanages.

At B.I. Verkin Institute for Low Temperatures, a volunteer group set up by Institute's young scientists is working actively. Their aim is to provide for the priority needs of the military at the hostilities line in the Kupiansk area.

Scientists of O.Ya. Usikov Institute for Radio Physics and Electronics, who are experts in subsurface radar detection, are consulting on a volunteer basis for in-depth training of the personnel of respective units of Ukraine's State Service for Emergencies as to operations with the *ALIS* (Advanced Landmine Imaging System) device — a mine detector with the Georadar function, donated by Japan for mine clearance of the territory of Ukraine.

Members of volunteer groups organized by research associates of E.O. Paton Electric Welding Institute fabricated and sent to the front more than 400 heating ovens. Institute's employees, volunteers and caring common Ukrainians joined the fundraising for oven materials and other needs of the AFU. Devices for electronic warfare, as well as loitering munitions, equipment for the construction of dugouts was procured and sent to military units. Fabrics for producing camouflage nets, along with money to buy a sniper rifle, were donated to other volunteer organizations. Money and medicines for an intensive care unit, personal hygiene products, medical equipment and materials for the

treatment and rehabilitation of the wounded military were donated to the Central Military Hospital.

Experts of I.M. Frantsevych Institute for Materials Science Problems produced anti-tank hedgehogs, developed the structure of specialized highly effective tripods for mounting machine guns on vehicles, and organized the fabrication of those.

Scientists of George Pukhov Institute for Energy Modeling of the NAS of Ukraine acted as volunteer advisors and consulted on organizing field radio communication, procuring, programming and using equipment, they directed the work of a volunteer group for developing and producing systems of autonomous radio reconnaissance and recording its results, fabricated adapters to stabilize and increase voltage for charging mobile devices by transport on-board networks in field conditions.

In response to the technical requirement of an Armed Forces unit, scientists of the Institute of General Energy developed and produced novel coupling devices for hauling heavy-weight military vehicles in critical situations.

The NAS Institute of Engineering Thermophysics produced and sent to the frontline 6500 instant rations to cook hot meals for servicemen.

The NAS Institute of Hydrobiology, jointly with the Ukrainian Fishermen's Association, organized a volunteer group for taking hydro-chemical, micro-biological and hydro-biological samples in the city of Kherson to check the changes of water quality in the Dnieper River after Russian troops blew up the dam of Kakhovka HPP.

Researchers of the NAS Institute of Cell Biology and Genetic Engineering were actively engaged in the activities of 'Tower over the Dnieper' volunteer community.

M.M. Gryshko National Botanical Garden held a number of charity exhibition-fairs of exotic plants, which brought over €250,000 for the needs of the Armed Forces. The greenhouse complex of the Botanical Garden continued its 'Garden Therapy' psychological rehabilitation program of for children. The greenhouses were visited by patients of the 'OKHMADYT' National Specialized Children's Hospital, internally displaced people from Bakhmut, Mariupol, Kramatorsk, the children wounded during hostilities and by those who had been under occupation. That was beneficial for their emotional and psychological state. Through a charity initiative, 'The Alley of Ukraine Defenders' was opened to commemorate men and women who fought and died for the nation. Besides, numerous free excursions were held for the personnel of Ukraine National Guard units, internally displaced persons, schoolchildren and teachers of Kyiv lycées and schools.

The team of the State Enterprise "V.K. Mamutov Institute of Economic and Legal Research" was efficient in providing various AFU units with equipment, clothes, tools and food. In particular, its scientists took part in

fundraising to purchase another automobile for the needs of the Armed Forces.

Oksana Kukuruz and Volodymyr Gorbatenko, employees of V.M. Koretsky Institute of State and Law, are active volunteers of the charitable foundation 'For the Sake of Ukraine'. The 'Source of Life' Health Festival organized by them presented little-known unique products of Ukrainian researchers; master classes were also conducted in the framework of 'Fenix' charity and rehabilitation program for the military and civilians.

Academician Mykola Zhulynsky, director of Shevchenko Institute of Literature, heads voluntary organization 'Hrushevsky Barricade — the Spirit of Great Warriors', which has been providing aid to the AFU since 2014. In 2023, the military received food products, medicines, generators, as well as "pocket-size" artistic editions published by scholars of the institution, in particular, books in the 'Ukrainian Warrior's Library' series etc.

Shevchenko Institute of Literature and Ivan Franko Institute were involved in organizing and holding the large-scale auction 'I am honored!' They raised funds for purchasing a *Mavic 3* Quadro copter and a thermal imager for the unit where Oles Fedoruk, scholar of the Institute of Literature, is fighting.

Natalia Torkut, research associate of Shevchenko Institute of Literature, is at the head of 'Shakespear' Volunteer Group, which is actively helping our military.

Scholars of Rylsky Institute of Art Studies, Folklore and Ethnology worked as volunteers both individually and as members of various associations. E.g., scholar Valentyna Sushko took part in the activities of charitable foundation 'Let Us Reconstruct Kharkiv Together' and 'EPL' volunteer Group. Lilia Ivanevych, research associate of the same institution, participated in the work of foundations 'Star Life Charity' and 'Headquarters 4.5.0'. During the presentation of her monograph dealing with traditional clothes of the Ukrainians of Podillia region, she organized fundraising for the Armed Forces. Liubov Bosa, employee of Ukrainian Ethnology Center of the Institute, organized a charity master class of py-sanka (Easter-egg) painting — all the money was transferred for the AFU needs. Fundraisers to support the AFU were also held during lectures and master classes provided in Poland by Institute's research associate Zinaida Kositska. Tetiana Nakonechna, who is also an employee of this Institute, was the curator of producing individual camouflage means and warm knitted products in the 'LvivOpir' volunteer center. Nearly 20 craftswomen were working under her guidance; they weaved camouflage costumes, cloaks, headpieces, camouflage covers for submachine and machine guns; 5 more women knitted warm socks and belts, little rugs for the military. Every two days they sent all that to the front, responding to both individual requirements of servicemen and those of military units.

SCIENCE POPULARIZATION, PUBLIC RELATIONS

Popularization of scientific knowledge and the results of scientists' work in a modern and understandable form for the broad auditorium is one of the areas of NAS activities. The search for new forms of cooperation between scholars, media and the public has been constantly going on. To enhance the presence of the Academy in the information space, its scientists are actively involved in TV and radio programs, publish articles on the pages of paper and Internet editions, maintain web pages in social networks, organize and participate in popular science events and projects. Every day, the official NAS site and its Facebook page publish interesting news and announcements dealing with Academy's life and activities that are of public interest.

Unfortunately, last year the realities and risks of the war time made us give up numerous traditional large-scale events, in particular, the All-Ukraine Science Festival and Science Days, aimed at popularizing scientific knowledge and work. Those who organized the events often had to use remote or mixed on-line — off-line format.

However, despite all difficulties and limitations, NAS institutions and scholars conducted continuous educating work and paid significant efforts to popularizing science and its achievements. E.g., in Kharkiv, a presentation exposition of the project "UPTI in Retrospect", devoted to the 95th anniversary of the Ukrainian Institute of Physics and Technology, was opened, and a number of thematic excursions at the NSC KIPT 'Old site' location and virtual tours of Piatykhvatky township were organized.

Last November, through the initiative of Kharkiv Oblast Military Administration and the North-East Science Center, celebration activities to mark the World Science Day for Peace and Development were held. The event had a very symbolic name — "Science Despite War" and gathered local authorities, scientists and education workers of the Kharkiv Oblast. Over the year, the National Scientific Natural History Museum invited children and adults to visit interesting excursions, quests, interactive programs, lectures, expositions addressing various subjects from the world of science and nature.

A number of exhibition events were held at M.M. Gryshko National Botanical Garden, among them were: the festival of science and plants at Botanical Garden *Fest of*

Science and Plants, 'Autumnal Vernissage', 'Christmas Vernissage' and others.

Academy scientists participated in the 'Days of the Field' activities held in Odesa Oblast and were also involved in marking the International Mathematics Day and the International Day of the π -number, which were aimed at popularizing mathematical knowledge.

The IInd Student Scientific Picknick *Academe Open Air 2023* organized by Kyiv Academic University and G.V. Kurdyumov Institute for Metal Physics was a noticeable event. During it, its participants had an opportunity to listen to interesting lectures delivered by NAS scientists and invited speakers, get acquainted with scientists, see implemented scientific projects, take part in faerie scientific experiments.

All those who were interested could visit traditional popular-science activities organized by research associates of the Main Astronomical Observatory of the NAS of Ukraine (MAO), in particular, 'The Day of Autumn Equinox', 'Astroautumn in Holosiiv'. Besides, direct broadcastings from the MAO were held, a series of educational scientific lectures 'Our Universe' and popular-science program 'Talks with Ivan Kriachko about the Universe' on YouTube Channel "Everything about the Universe" continued to be released.

For the first time after a long pause, the Scientific and Technological Complex 'Institute for Single Crystals' organized an introductory tour for schoolchildren under the slogan 'Science is Cool!' Kharkiv schoolchildren visited the exhibition of the S&T Complex, where they could see with their own eyes and hold laboratory specimens and prototypes in their hands.

NAS scientists continued their work in the popular-science lecture cycle *Science Kids* on the *INSCIENCE* platform. During webinars, young listeners could learn about the emergence of the world and the development of life, about man and nature, secrets of space etc. Besides, Academy scientists popularized science in the framework of the 'True Science' project, and were also the guests of the popular-science podcast 'Main Observatory' on *Ukrainska Pravda* media resource.

In 2023, the action "We Are Opening Science to Everyone" was continued — the web resource of *Academperiodyka* Publishing House opened free access to its new books.

Svitohliad popular-science magazine, which is published by the Academy in collaboration with the Main Astronomical Observatory, was issued regularly. Discussions on the global challenges of the 21st century, science issues and achievements were continued on its pages. The work of Kharkiv Chemistry Seminar, set up by scientists of the research department of functional materials chemistry at NAS S&T Complex 'Institute for Single Crystals', where renowned chemistry scientists of the world deliver lectures, continued. In 2023, 16 lec-



Meeting of NAS President academician Anatoly Zagorodny and Academy Vice-President, NAS corresponding member Oleg Rafalskyi with Richard Stone, senior editor of *Science* magazine



Interview of academician Igor Kryvtsun, director of E.O. Paton Electric Welding Institute of the NAS of Ukraine

tures were given, during which leading professors of the USA, Switzerland, Italy, the Czech Republic and other countries shared their research experience. All in all, since the beginning of the Kharkiv Chemistry Seminar over 30 lectures were organized, which involved more than 9000 participants (both directly at meetings and through the *YouTube* channel). The events were announced on the official NAS site and on its Facebook page.

The program "Competently about Science" continued to appear regularly on the YouTube channel of the NAS of Ukraine and increased its popularity. In their interviews to academician Volodymyr Semynozhenko, leading scientists in nuclear energy, general and inorganic chemistry, cell and molecular biology, issues of artificial intelligence, archeology, economics, demography, sociology, philosophy told their audiences about the latest research and developments aimed at important challenges of the Ukrainian society and state. Last year, there were 23 program releases.

In 2023, scholars of the NAS of Ukraine actively cooperated with Ukrainian media.

Apostroph TV channel, in close cooperation with the Academy, prepared and released a cycle of TV programs *Security Talks* involving the leadership and prominent scientists of the NAS of Ukraine. In their interviews to program host Valentin Badrak, scientists spoke about their developments for the security and defense of our state, Academy's potential for the post-war reconstruction of Ukraine, the work of scholars in socio-humanities on debunking the myths of Russian propaganda etc.

Over the year, the active cooperation with foreign media was going on. Journalists focused on the state of scientific field in Ukraine and peculiarities of Ukrainian scientists' work during the war, the forms of international support to scientists, the destruction caused and the losses inflicted, especially those on the front-line territories, along with the search for ways of restoring scientific infrastructure. During his visit to Ukraine, Richard Stone, senior scientific editor of the American scholarly magazine *Science*, visited the Academy. He communicated with the Academy leadership and visited several NAS institutions. With the reliance on the visit results, *Science* magazine published an article describing Ukrainian scientists' studies of the devastating environmental impacts of exploding the Kakhovka HPP dam.

Last November, Mats Larsson, professor of Stockholm University, member of Nobel Committee in Physics, and Erik Aurell, professor of Royal Technological University, visited Ukraine at the invitation of the Academy. High guests from Sweden delivered lectures, which were attended by members of the National Academy of Sciences, research associates of its institutions, pupils of Kyiv Natural Science Lycée № 145.

In April 2023, at the regular session of the General Meeting of the National Academy of Sciences of Ukraine, the NAS Prize 'For Popularizing Science' (according to the competition results of 2022) was handed for the first time. The Prize laureates were determined in three nominations. The Prize committee chose the best popular-science publication (series of publications) of a printed/electronic media, the best program about science and the best educational science project. A representative of foreign media was among the first winners of the Prize.

The competition for the 2023 NAS Prize 'For Popularizing Science' has already been announced. It is awarded to media and their representatives, scientists and managers of independent projects for the best material about scientists' achievements, activities of Academy research institutions and the NAS of Ukraine in general, as well as promoting science popularization and raising the profession of scientist in Ukraine.

APPRECIATION OF NAS SCIENTISTS' ACHIEVEMENTS

Awarded with V.I. Vernadsky Gold Medal of the NAS of Ukraine were NAS academician V.P. Gorbulin for his outstanding achievements in developing the scientific foundations of the national security and defense capability and NAS Foreign Member professor Janusz Katzprzyk (Poland) for prominent achievements in the field of artificial intelligence, decision-making theory and robototechnics.

B.E. Paton Gold Medal of the NAS of Ukraine was awarded for the first time to NAS academician L.M. Lobanov for developing the technology of deformation-free welding, developing and implementing laser interferometry methods for assessing welded joints, and to Oleg Korostyliov, Director General of the 'Luch' State Design Bureau of Kyiv, NAS corresponding member, for developing and organizing the series manufacturing of novel types of weaponry and military products.

In 2023, 7 employees of NAS institutions, organizations and enterprises were honored with state awards. For personal courage and heroism in defending the national sovereignty and territorial integrity of Ukraine, devoted service to Ukrainian people, with the title 'Hero of Ukraine', and awarding 'Golden Star' Order, was honored B.R. Sharopov, research associate of Bogomolets Institute of Physiology, (posthumously).

For personal courage in defending the state sovereignty and territorial integrity of Ukraine, devoted fulfilling their military duty, awarded were:

with order 'For Courage' II Class — A.O. Nazarenko, senior research associate of the department of monitoring and diagnostics of energy facilities of the NAS Institute of General Energy;

with order 'For Courage' III Class — R. O. Kozlenko, director of 'Olbia' National History and Archeology Reserve.

For significant merit in strengthening Ukrainian statehood, courage and devotion in defending the sovereignty and territorial integrity of Ukraine, considerable personal contribution to developing various spheres of social life, conscientious performance of professional duties, awarded were:

V.M. Hraboyi, acting director of Sofiiivka National Dendrological Park, — with order 'For Merit' III Class;

S.S. Dembitskyi, deputy head of the NAS Institute of Sociology, — with medal 'For Labor and Victory';

For their significant personal contribution to the development of national education, training of high-qualification personnel, courage and dedication demonstrated in defending the sovereignty and territorial integrity of Ukraine, fruitful pedagogical activities and high professionalism, G.O. Polishko, department head of E.O. Paton Electric Welding Institute, and N.D. Shcherban, senior research associate of L.V. Pisarzhevsky Institute of Physical Chemistry, were honored with medal 'For Labor and Victory'.

The honorary title 'Merited Doctor of Ukraine' was given to O.I. Pleguka, Head Doctor of the State Scientific Institution "The NAS Center for Innovative Medical Technologies".

For providing comprehensive aid during Russian Federation's armed aggression against Ukraine, fruitful cooperation with the Armed Forces of Ukraine, patriotism and proactive public position, decorated with the Ministry of Defense award 'For Aid to the Armed Forces of Ukraine', NAS corresponding member V.P. Babak, acting director of the NAS Institute of General Energy, I.V. Didenko, deputy director for general issues, and N.I. Sokolovska, head of research management of this institute, were honored with medal 'For Aid to the Armed Forces of Ukraine'.

The 'Golden Cross' breast-worn sign from the Head Commander of the Armed Forces of Ukraine went to G.S. Tersimonov, post-graduate student of Bogolyubov Institute for Theoretical Physics, and the breast-worn sign 'For Aid to the Armed Forces' was handed to A.I. Senenko, senior research associate of the Institute of Physics.

The Cabinet of Ministers Prize was given to one scientist, that of Kyiv Mayor — to six young researchers. 12 Academy employees and 2 work teams were marked with Verkhovna Rada Diplomas and 2 — with Verk-



Handing V.I. Vernadsky Gold Medal to NAS academician Volodymyr Gorbulin



Junior research associate of the NAS Institute for Problems of Cryobiology and Cryomedicine PhD Fedir Hladkykh — the winner of the contest “The best young scientist of the Academy — 2023”



NAS prize ‘For popularizing science’ was handed to Tetiana Bulyhina, research associate of D.K. Zabolotny Institute of Microbiology and Virology of the NAS of Ukraine

hovna Rada Honorary Diplomas, while Kyiv Mayor Prize went to 8 young NAS scientists. 12 Academy employees and 2 work teams were marked with the Diploma and Honorary Diploma of the Verkhovna Rada of Ukraine.

Achievements of Academy scholars won a number of awards of leading international and foreign organizations. Shao annual international scientific prize in mathematics was awarded to V.G. Drinfeld, professor of mathematics of Chicago University (USA), corresponding member of the NAS of Ukraine.

Humbolt Research Award went to Yu.L. Maistrenko, leading research associate of the laboratory of mathematical modeling of non-linear processes, operating under NAS Technical Center and the Institute of Mathematics, for his scientific achievements in studying non-linear dynamics and complex systems, their mathematical modeling and applications, as well as a fundamental contribution to the study of complex networks and chimera states.



Bizhan Sharopov, a young scientist of the Academy, was awarded the “Hero of Ukraine” title (posthumously) for personal courage and heroism in defending the state sovereignty and territorial integrity of Ukraine

A prestigious international prize in mathematics — “Joseph F. Traub Information-Based Complexity Young Researcher Award 2023” was given to K.V. Pozharska, young research associate of function theory department of the Institute of Mathematics, for her significant contribution to information complexity theory.

By Georg Forster Research Award in the recognition of significant achievements in science and education was awarded to NAS corresponding member I.O. Frytskyi, head of physical chemistry chair at the Chemistry Department of Taras Shevchenko National University of Kyiv, corresponding member of the NAS of Ukraine.

2022 Ito Prize, which commemorates professor’s Kiyosi Ito’s legacy, his enormous and fundamental contribution to probability theory and application of stochastic processes, was received by A.Yu. Pylypenko, leading research associate of the department of occasional processes at the NAS Institute of Mathematics.

The Alloy Phase Diagram International Commission (APDIC) awarded the prize “Best Paper Award 2022” in the field of state diagrams and related disciplines to 4 research scientists of I.M. Frantsevich Institute for Materials Science — K.Ye. Korniyenko, K.A. Meleshevych, L.S. Kryklia and A.V. Sameliuk.

The Holodomor Research and Education Consortium (HREC) at Alberta University (Canada) honored O.R. Kis, head of NAS Ethnology Institute’s social anthropology department, with prestigious international Robert Conquest Prize for her article “Women’s experience of the Holodomor: Challenges and Ambiguities of Motherhood”.

Two Academy woman scientists — O.V. Larina, senior research associate of L.V. Pisarzhevsky Institute of Physical Chemistry, and N.Ye. Stasiuk, senior research associate of the Institute of Cell Biology, — became the winners of the V Ukrainian L’ORÉAL — UNESCO prize “For women in science”, set up by L’ORÉAL company in 1998.

M.Z. Lehkyi, the head of Franko studies department at Ivan Franko Institute, became the laureate of the International Ivan Franko Prize for his profound scholarly monograph and many years of research in the field of Franko studies.

NAS corresponding member Ye.I. Golovakha, director of the NAS Institute of Sociology, became one of the three laureates of the *Talents for Ukraine* program of the Kyiv School of Economics *KSE Foundation*.

K.M. Shmega, acting academic secretary of Ivan Franko Institute, received Mykhailo Vozniak Prize in Culture, Literature, Arts, Journalism, and Architecture in the nomination 'Literature studies, current literature criticism and translations'.

Academy scholars became the winners of numerous NAS prizes, they received various departmental distinctions for personal professional achievements and active public work.

46 Academy researches became the laureates of NAS prizes named after outstanding scientists of Ukraine.

"The best young scientist of the Academy — 2023" contest winners, which last year was carried out for the first time, determined 15 laureates in the nominations: Information sciences and mathematics; Physics and astronomy; Engineering sciences; Earth and sustainable development sciences; Materials sciences; Nanotechnologies; Energy; Chemistry; Biology; Biotechnology; Economics, Management and sociology; History, philosophy and law; Literature, language, ethnology and art studies.

9 persons became the winners of the NAS prize "For Popularizing Science". The Academy set it up last year,

to be awarded to mass media and their individual representatives, scientists and administrators of individual projects for the best material on Academy scientists' achievements, the NAS research institutions in general, as well as for promoting science popularization and enhancing the prestige of scientist's profession in Ukraine.

In 2023, 216 persons received Academy distinctions: 27 — "For scientific achievements"; 58 — "For training young scientists"; 89 — "For professional achievements"; 13 — "For promoting science advancement"; 29 received the "Talent, inspiration, work" distinction for young scientists.

153 researchers and 20 work teams were distinguished with NAS commendations on the occasions of memorable dates, for fruitful work, significant contribution to science development; 148 employees and 2 work teams were awarded with the Honorable Diploma of the NAS Presidium and the Central Trade Union Committee of NAS employees.

To honor personal courage and patriotism in defending the sovereignty, independence and territorial integrity of Ukraine, 344 Academy employees who took a direct part in rebuffing Russian armed aggression received NAS commendations.

171 employees were marked with NAS commendations for their personal contribution to science administration, economic and technical support to the functioning of Academy institutions during the full-scale Russian aggression, active charity and volunteer work; 86 employees received the Honorary Diplomas of the NAS Presidium and the Central Trade Union Committee of NAS employees.

BACKGROUND INFORMATION. STATISTICS

Structure of the NAS of Ukraine

The structure of the NAS of Ukraine includes 3 sections and 14 departments, which incorporate 145 research institutions. Research-and-production organizations (design offices, pilot production facilities etc.) operate within some scientific institutions. Functioning within some research institutions are science objects that have the status of National Asset (nuclear, physical and astronomical research facilities, testing equipment complexes, archive scientific collections and museum displays, plant genetic funds, collections of microorganism strains and plant lines, cell banks, landmarks of history and culture etc.), as well as centers for shared use of scientific equipment.

Research organizations that have the National Institution status:

- V.I. Vernadsky National Library of Ukraine
- National Science Center "Kharkiv Institute of Physics and Technology"
- "Olbia" National Historical and Archeological Reserve
- M.M. Gryshko National Botanical Garden
- "Sofiivka" National Dendrological Park
- National Museum of Natural History
- V. Stefanyk National Scientific Library of Lviv
- National Center "Junior Academy of Sciences" of the MES of Ukraine and the NAS of Ukraine.

Functioning in the Academy are **five Regional Science Centers** of dual subordination to the NAS of Ukraine and the Ministry of Education and Science of Ukraine:

- Donetsk Science Center (Kramatorsk, Donetsk oblast)
- Western Science Center (Lviv)
- Southern Science Center (Odesa)
- North-East Science Center (Kharkiv)
- Prydniprovskiy Science Center (Dnipro), as well as the Center for Evaluating Research Institutions and Scientific Support to the Development of Ukraine Regions (Kyiv).

The statutory activities of Crimean Science Center and its funding from the NAS budget were suspended in 2014.

DISTRIBUTION OF INSTITUTIONS ACROSS SECTIONS AND DEPARTMENTS

Department	The number of scientific institutions	The number of R&D organizations	Objects with the National Asset status	Centers for shared use of research equipment
Section of Physical, Engineering and Mathematical Sciences				
Mathematics	3	—	—	—
Informatics	8	—	—	1
Mechanics	7	3	3	3
Physics and Astronomy	13	2	10	16
Earth Sciences	13	1	1	5
Physical & Engineering Problems of Materials Sciences	12	17	2	12
Physical & Technological Problems of Energy Engineering	10	1	2	4
Nuclear Physics & Energy Engineering	5	2	2	6
Section of Chemical and Biological Sciences				
Chemistry	13	11	—	11
Biochemistry, Physiology & Molecular Biology	8	2	5	9
General Biology	21	1	19	12
Section of Social Sciences and Humanities				
Economics	9	—	—	—
History, Philosophy & Law	16	3	5	—
Literature, Language & Art Studies	7	—	4	—

Regional structure of the NAS of Ukraine

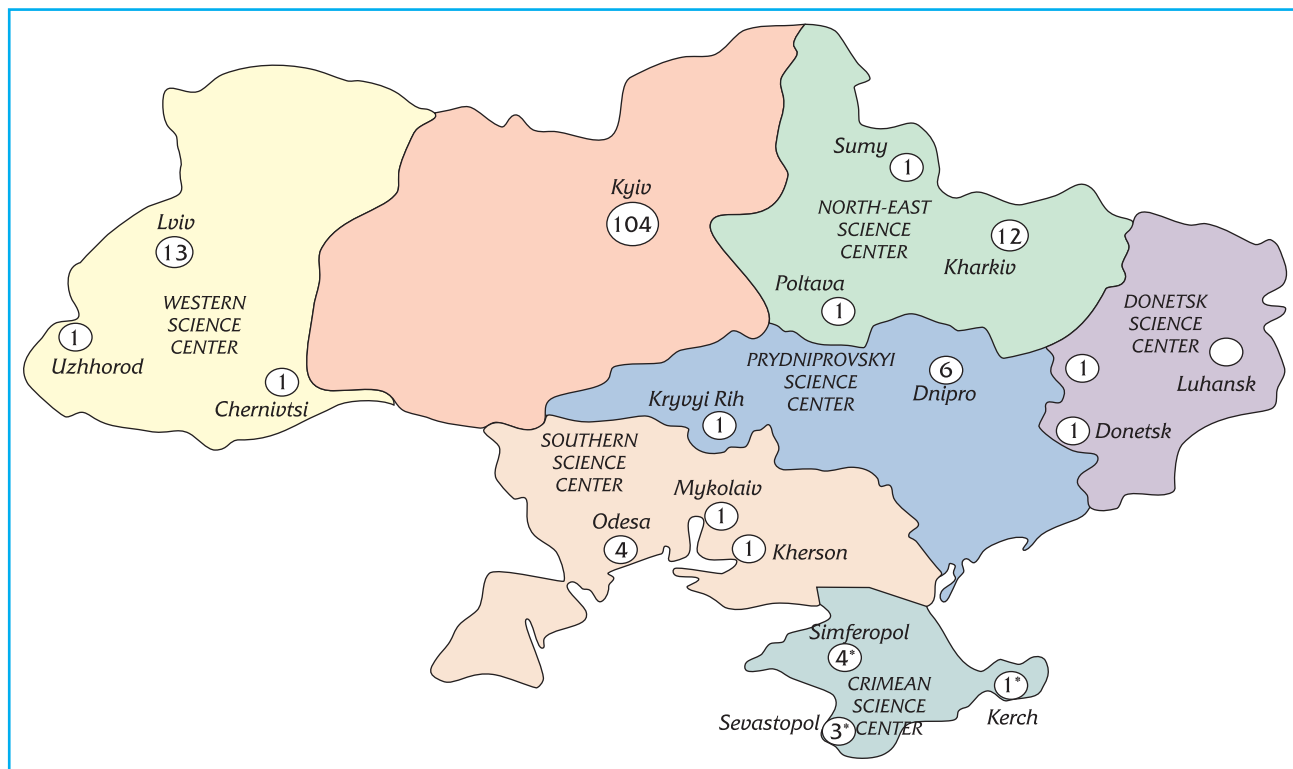

Figures in the map show the number of research institutions
 * The status of NAS institutions located in the Autonomous Republic of Crimea is defined by the Law of Ukraine 'On guaranteeing the rights and freedoms of citizens and legal regime on the temporarily occupied territories of Ukraine'

Conducting scientific research

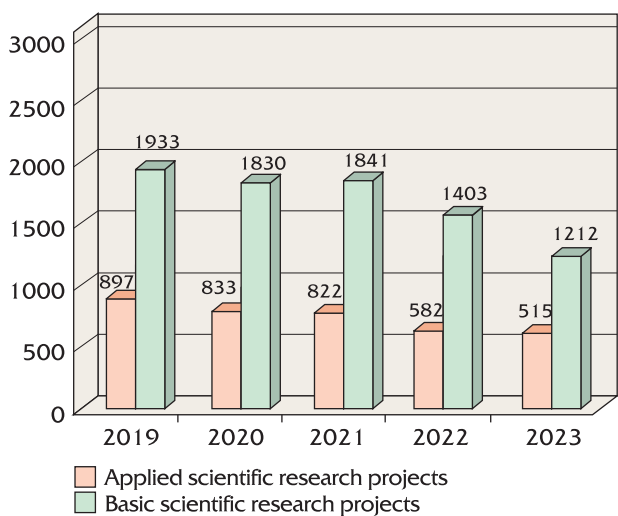

The number of currently implemented research projects financed from the general fund of the State Budget

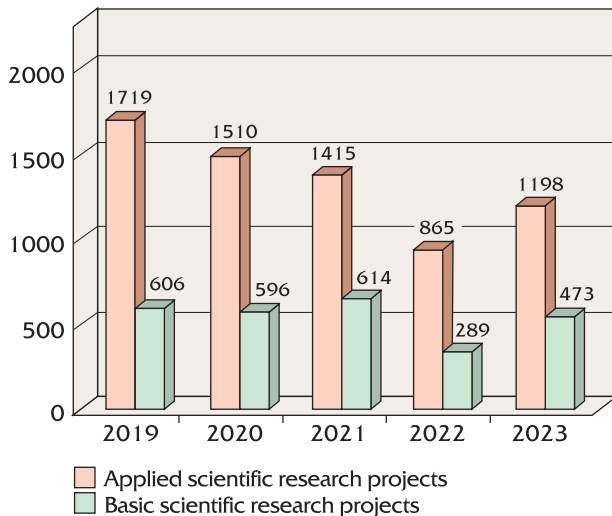

The number of currently implemented research projects financed from the special fund of the State Budget

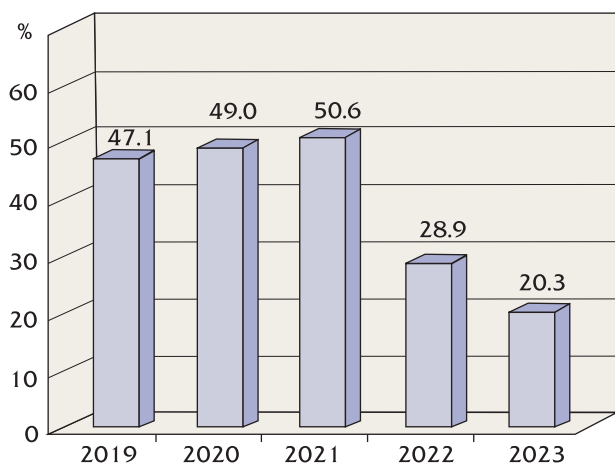

The part of targeted-program and contest-based topics of NAS institutions in the total number of research projects

Targeted-program and contest-based research projects of the NAS of Ukraine in 2023 involved the research conducted under:

- 1 NAS targeted program of basic research;
- 3 NAS targeted programs of applied research;
- 26 targeted research projects;

and were based on the results of:

- joint contests with foreign and international organizations;
- contest of scientific and S&T projects implemented in the area 'Support to scientific and S&T (experimental) developments that are of top priority for the state';
- contests of research projects of young scientists of the NAS of Ukraine;
- NAS grants to research laboratories/groups of young NAS scientists for conducting research in priority areas of science and technology.

Publication activity

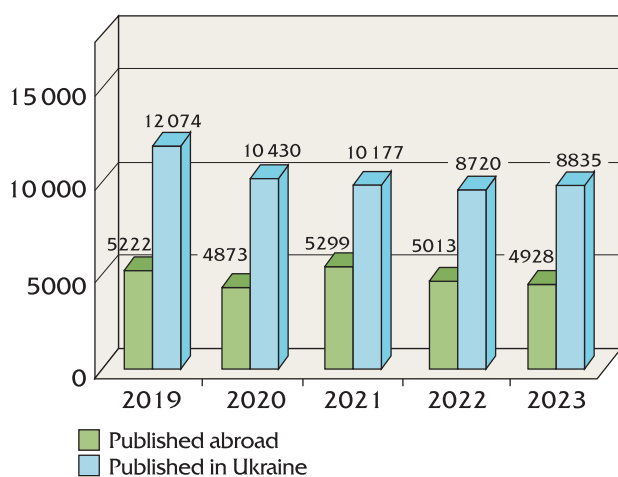

Papers by NAS scientists in periodicals

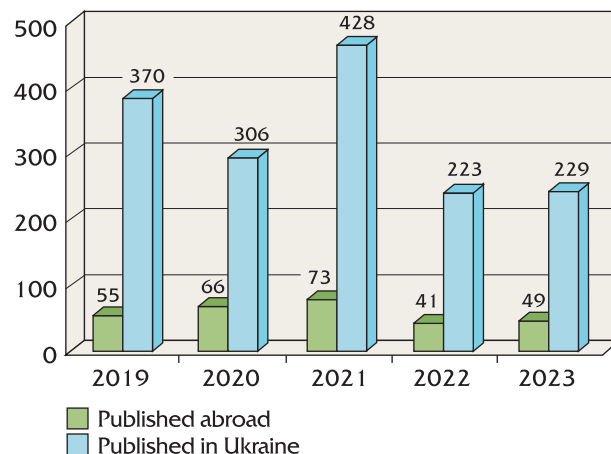

Scientific monographs

Publishing activities

• **the total number of Academy journals:**

83 scientific journals, 1 popular-science journal (*Svitohliad*), and *Dzherelo* abstract journal in four series;

• **12 journals are published in English in Ukraine:**

1. Science and Innovation
2. Semiconductor Physics, Quantum Electronics & Optoelectronics
3. Journal of Mathematical Physics, Analysis, Geometry

• **14 journals are published in English abroad:**

4. The Paton Welding Journal
 5. Progress in Physics of Metals
 6. Journal of Thermoelectricity
 7. Ukrainian Journal of Physics
 8. Functional Materials
 9. Biopolymers and Cell
 10. Experimental Oncology
 11. Problems of Cryobiology and Cryomedicine
 12. Zoodiversity
- by Springer Publishers
1. Ukrainian Mathematical Journal
 2. Cybernetics and Systems Analysis
 3. International Applied Mechanics
 4. Strength of Materials
 5. Materials Science
 6. Theoretical and Experimental Chemistry
 7. Neurophysiology
- by Allerton Press Inc.
8. Kinematics and Physics of Celestial Bodies
 9. Journal of Superhard Materials
 10. Journal of Water Chemistry and Technology
- by Begell House Inc. Publishers
11. Cytology and Genetics
 12. International Journal on Algae
 13. Hydrobiological Journal
- by other publishers
14. Low Temperature Physics (American Institute of Physics)

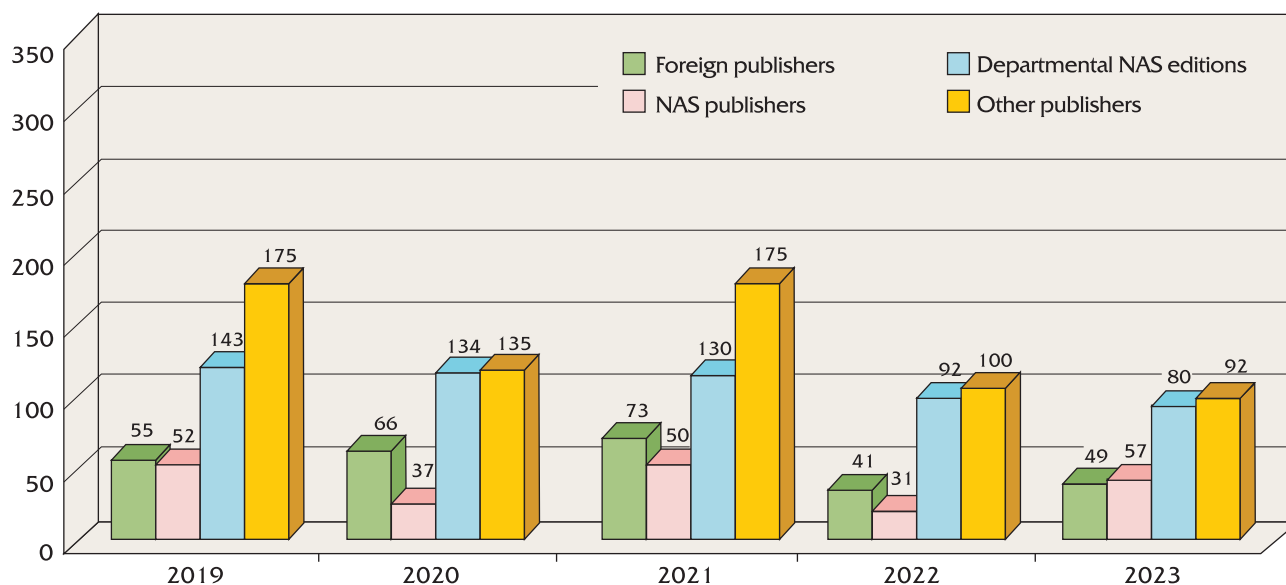

Distribution of scientific monographs across publisher groups

Scientific expert activities

In 2023, NAS scientists were involved in preparing:

- Strategy of developing space activities of Ukraine out to 2033;
- Strategies of developing education and science in Ukraine for 2023—2032;
- State strategy of advancing science, technologies and innovative activities;
- State targeted economic program of developing titanium industry in Ukraine;
- Strategy of developing relations with the countries of Latin America and the Caribbean Basin;
- National report on the state of natural environment in Ukraine in 2022.

Expert conclusions, notes, proposals were prepared, in particular those concerning the legislation drafts:

- 'On introducing amendments to some legislation acts of Ukraine concerning the development of electronic trade in alternative fuels';

- 'On introducing amendments to some laws of Ukraine concerning renovation and "green" transformation of Ukraine's energy system';
- 'On the state-wide targeted ecological program of radioactive waste management';
- 'On the state regulation of activities in the sphere of technology transfer';
- On mobilizational training and mobilization';
- 'On introducing amendments to Criminal and Criminal Procedure Codes of Ukraine concerning the improvement of responsibility for some crimes against the foundations of the national security of Ukraine';
- 'On the implementation of international humanitarian law in Ukraine';
- 'On introducing amendments to some laws of Ukraine concerning support to scientific research work at the institutions of higher education';
- 'On introducing amendments to some legislation acts of Ukraine concerning increasing the efficiency of protecting nature territories and objects of nature reserve fund'.

Expert conclusions	2019	2020	2021	2022	2023
Concerning normative legal acts and program documents, information and analytical materials on various issues of socio-economic development provided to state power bodies	2330	1850	1900	1800	1730
Concerning the expediency of funding basic research projects from the State Budget	428	1081	440	412	279

Innovation activities

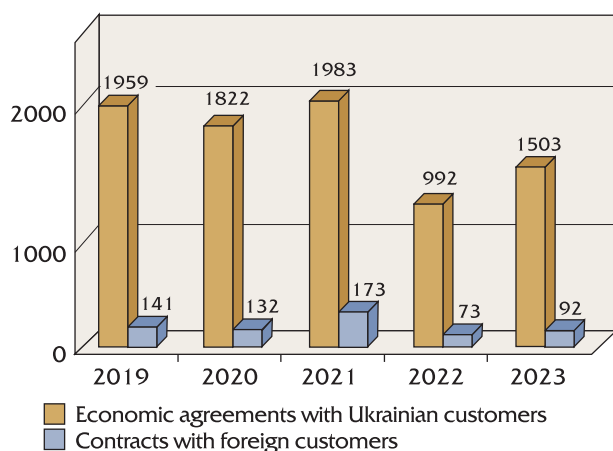

The number of economic agreements and contracts

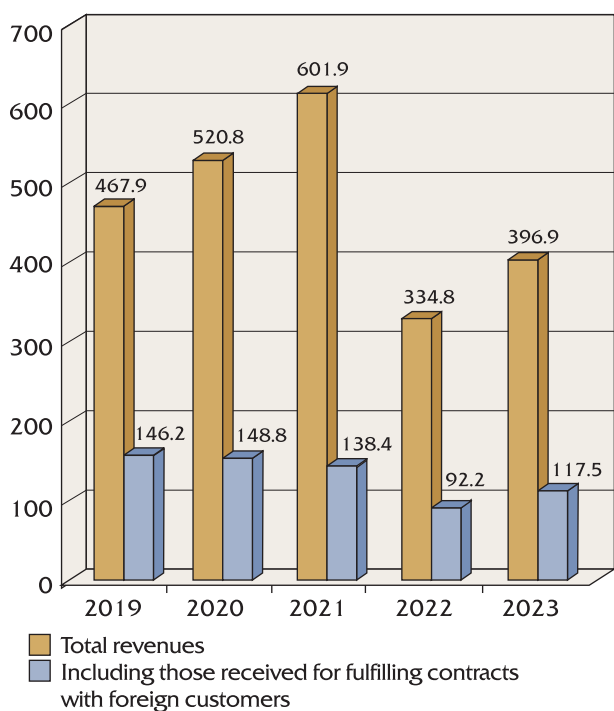

Revenues received by NAS institutions for fulfilling economic agreements and contracts *2 million*

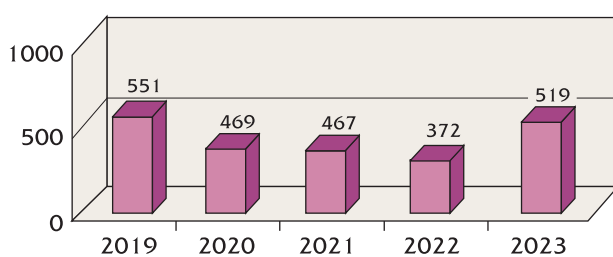

The number of deployed scientific products

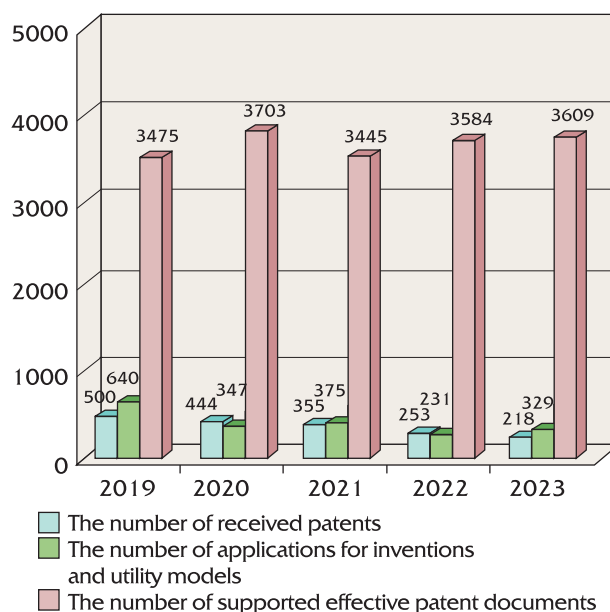

Protection and use of intellectual property objects, the number

Cooperation with institutions of higher education and institutions of the MES of Ukraine

Collaboration agreements concluded between research institutions and institutions of higher education	253
Research topics and projects developed in collaboration with academics	128
Published monographs co-authored with academics	95
Research scientists who worked in education:	1140
including:	
NAS academicians	38
NAS corresponding members	65
Published monographs in collaboration with education workers	116
Scientists at the head of chairs in institutions of higher education	55
Students of higher education institutions who pursued/are pursuing Master's degree programs at joint research-and-training facilities hosted by scientific organizations:	
in academic year 2022/2023	699
in academic year 2023/2024	417
Students who prepared their graduation papers at research institutions	960
Education workers incorporated to specialized academic councils of research institutions	366
Scientists of research institutions incorporated to specialized academic councils of the institutions of higher education	375

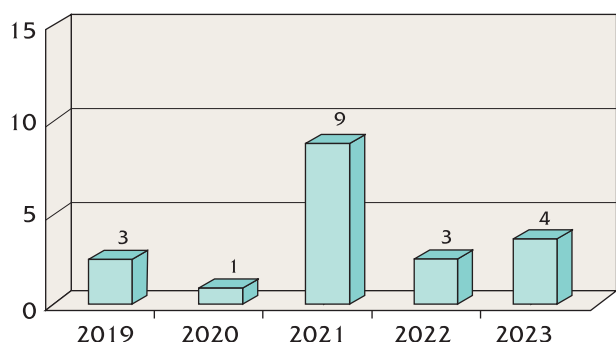

Joint research-and-training facilities

Newly employed graduate specialists at research institutions who attended study groups of the Junior Academy of Sciences in their school days 4

Research scientists and lecturers of the institutions of higher education and MES organizations who upgraded their professional skills at research institutions 328

Theses of education workers defended at specialized academic councils of scientific research institutions 19

International ties

Legal contractual framework for the international cooperation of the NAS of Ukraine (effective agreements, contracts, memorandums etc.) – a total of 132 documents.

In 2023, the Academy signed:

- Memorandum of understanding between the National Academy of Sciences of Ukraine and *Leopoldina* National Academy of Sciences of Germany;
- Memorandum of understanding between the National Academy of Sciences of Ukraine and the US Civilian Research and Development Foundation (*CRDF Global*).

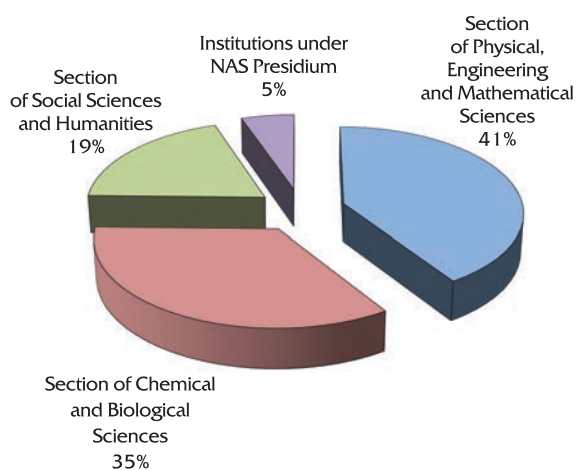

Distribution of direct agreements and contracts across institutions of NAS sections

Over 700 direct agreements and contracts concluded by NAS institutions with international partners are in force. Of those, 267 were concluded by the institutions of the Section of Physical, Engineering and Mathematical Sciences, 228 — by institutions of the Section of Chemical and Biological Sciences, 128 — by those of the Section of Social Sciences and Humanities, 35 — by the institutions under NAS Presidium.

Employment figures (as of 01.01.2024)

Total number of employees	24 980
of them:	
at research institutions	24 065
at pilot production facilities	723
at service organizations	192
Number of research scientists	13 444
of them:	
doctors of sciences	2 340
candidates of sciences (PhDs)	6 333
researchers without advanced degrees	4 771
The number of young specialists recruited in 2023	192
The number of those who pursued post-graduate studies in 2023	1 353
including those engaged in full-time studies	1 269
Defended candidate-of-science or PhD theses	115
of those — candidate-of-science theses	19
Doctoral fellowships	156
Defended doctor-of-science theses	10

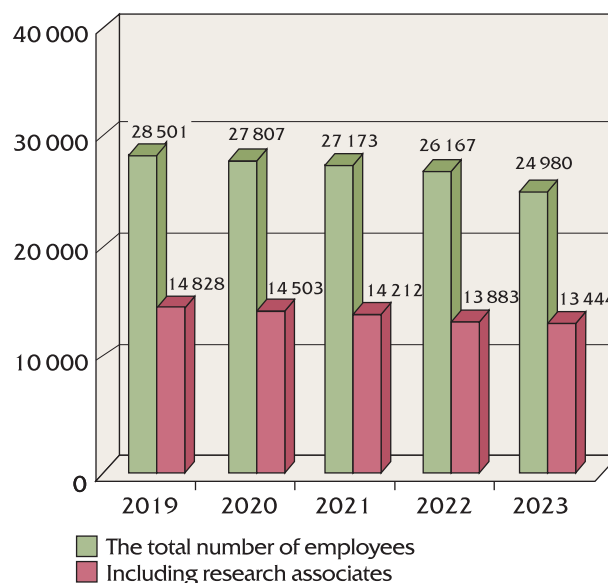

The number of employees

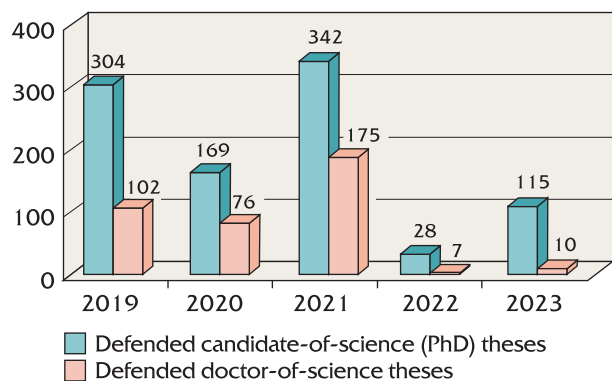

Training of scientific personnel, the number of persons

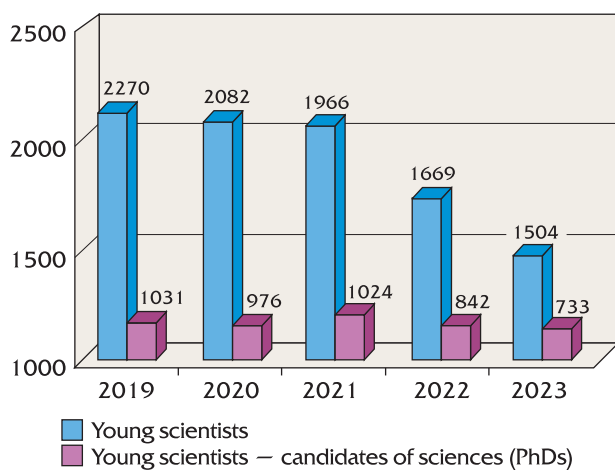

The number of young scientists

Financial provision

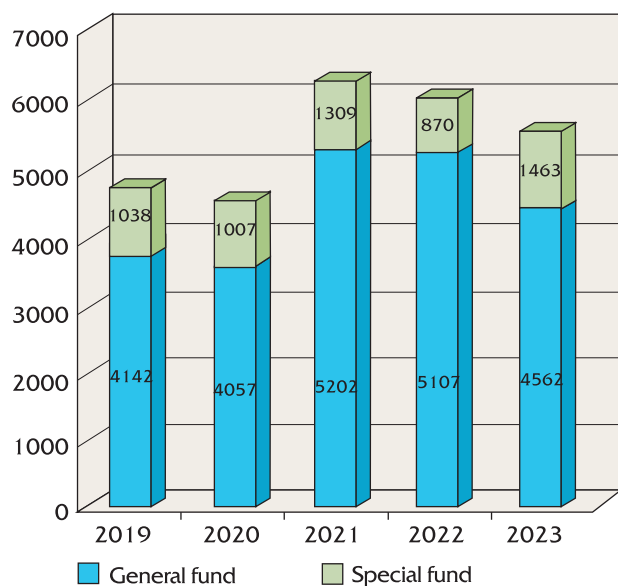

The total amount of NAS funding, € million

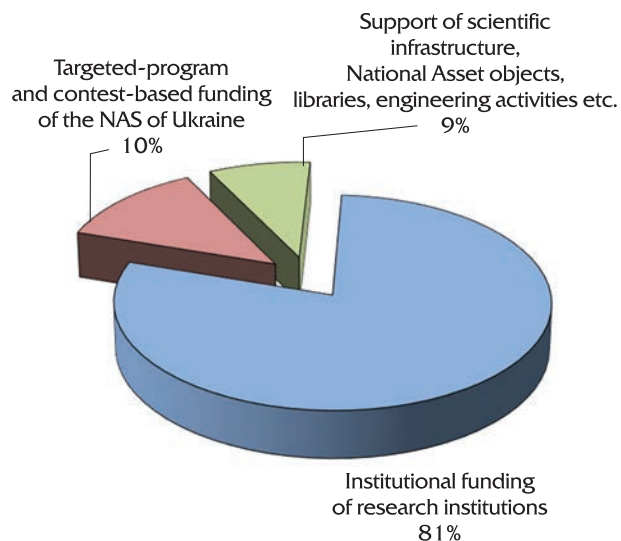

Distribution of general fund finance for conducting scientific research

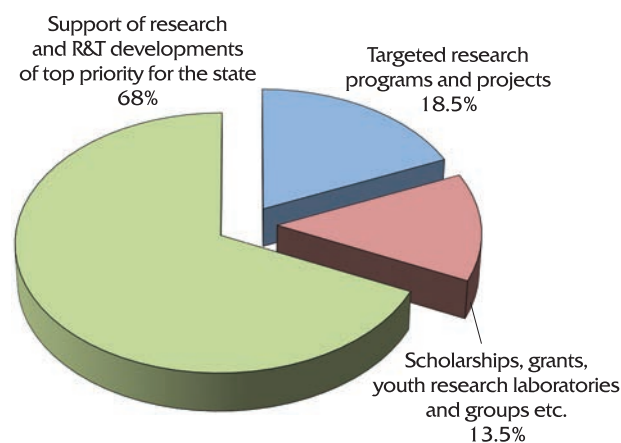

Targeted-program and contest-based funding

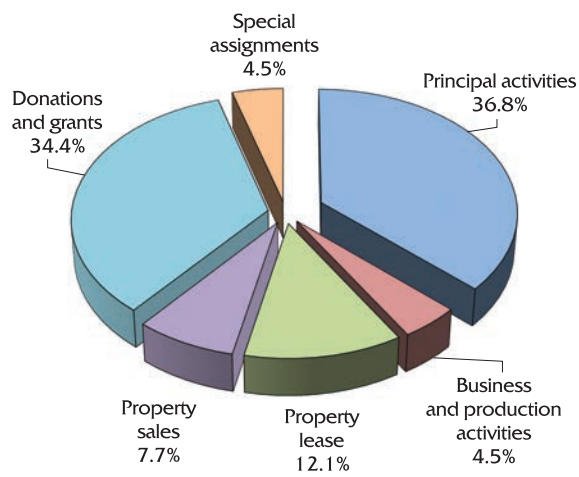

Structure of revenues to special fund