

FOREWORD OF THE PRESIDENT OF THE NATIONAL ACADEMY OF SCIENCES OF UKRAINE ANATOLY ZAGORODNY

Dear colleagues! The National Academy of Sciences of Ukraine, like the whole Ukraine, the whole Ukrainian people, is going through the hardest times in its modern history.

Our state and society were faced with new challenges caused by an unprovoked large-scale aggression of Russia against Ukraine. For the scientific community, this was both the substantial deterioration of conditions (for some researchers also the impossibility of highly qualified work) and the forced departure abroad, as well as a slowdown of the planned reforms in scientific sphere and breakdown of established international relations.

The Russian aggression inflicted huge losses on Ukrainian science, damaged scientific institutions, destroyed scientific infrastructure facilities, took the lives of our colleagues. However, in that very difficult situation, the Academy is working and maintaining its viability.

Regular meetings of the NAS Presidium heard a number of presentations, primarily, those whose results can be used for enhancing the defense capability of Ukraine and for minimizing the impacts of hostilities. Much attention was given to debunking myths and disinformation generated by the aggressor's propaganda machine.

The Academy actively used scientific diplomacy, broadly informed world academic and research community about terrible consequences of the Russian invasion, sent numerous appeals for the disapproval of the Russian armed aggression, calls to stop the war unleashed against Ukraine and terminate any scientific cooperation with institutions and scientists of the aggressor country, which was immediately done by the National Academy of Sciences of Ukraine.

Today the efforts of Academy's scientists are focused, first of all, on the research and developments aimed at strengthening the defense capability and security of the nation, scientific support to solving problems that are of utmost importance for the state and society, and on

further advancement of basic research in the priority trends of global science. The proof of that were significant R&D results produced in 2022.

I cannot help but acknowledge the volunteer assistance which our scientists are providing to the Armed Forces of Ukraine. They produce and send to medical institutions and to military on the frontline their new developments — medicines and medical equipment, materials for bulletproof vests etc. They deliver welding materials, portable autonomous solar power plants, mobile heating furnaces and autonomous power supply systems. They support with their own finance the projects of providing the Armed Forces of Ukraine with innovative devices for surveillance and intelligence.

Despite our plans and aims having been disrupted by the Russian large-scale armed aggression, we continued to improve Academy's activities, optimize its structure, the principles of its organization and functioning. The main lines of this work were determined by the Concept of Developing the NAS of Ukraine in 2021—2025. Certain measures were taken towards improving the efficiency of using budget funds, the support of young researchers.

The work of the Science and Technology Council of the NAS of Ukraine, of the science coordination councils of NAS sections was started. A new version of the methodology of evaluating the efficiency of scientific institutions' activities was approved. Much effort was made for attracting the support of international and foreign organizations.

Academy's priorities, at least those in the near future, are, in my view, evident. First and foremost, we must do everything possible to retain the human potential and leading teams of scientific institutions, restore and develop scientific infrastructure. No doubt, R&D of Academy institutions must be directed at enhancing the defense capability and security of the state, identifying and solving new important tasks in this sphere. And of no less importance is to involve as many foreign partners as possible in supporting our own research in Ukraine and providing the necessary advanced equipment.

Dear colleagues! We are destined to live and work under superheavy pressure. However, even in such hard times our scientists have the courage, and what is most important, the desire to be engaged in science, achieving significant results. There are all reasons to say that they are the most valuable treasure of the National Academy of Sciences of Ukraine. And these very people inspire confidence in the worthy future of our Academy.

Let me express to each of you my respect and give the words of profound gratitude for your courage, heroism and fortitude!

I am sure that by joining efforts we will withstand all difficulties!

We will overcome and win!

IMPORTANT EVENTS, ORGANIZING NAS ACTIVITIES UNDER MARTIAL LAW

On February 2022, a scientific session of the NAS General Meeting addressing the formation and implementation of the development model of low-carbon economy in Ukraine was held. The event was attended by leading NAS scientists, representatives of Ukraine's ministries and government departments.

Opening the session, the President of the National Academy of Sciences of Ukraine Anatoly Zagorodny emphasized that climate change and environmental problems stemming from it are now the center of attention of the whole world. At the 26th UN Conference on Climate Change, which took place in October 2021 in Glasgow (Scotland), over 180 UN member states, Ukraine in particular, declared that in 2050—2060-ies they are to achieve net-zero greenhouse gas emissions, and our state was one of the first to declare its Low Emission Development Strategy out to 2050. However, dealing with the challenges of climate change, providing sustainable development of Ukraine cannot be achieved merely through the efforts of power structures or expert community. "Continuous comprehensive scientific support is of utmost importance for that", Anatoly Zagorodny stressed.

Presentations at the session were made by: NAS academician Valerii Heyets ("Ukraine's economy in the imperatives of low-carbon development"), NAS academician Olexandr Kirilenko ("Ways and means of transforming Ukraine into an intelligent environmentally safe system"), NAS academician Anatolii Nosovskiy ("Nuclear energy of Ukraine in the context of sustainable development"), NAS academician Yurii Solonin ("Advancement of hydrogen energy research in the world and in Ukraine"), NAS academician Yakiv Didukh ("The role of Ukraine's natural ecosystems in providing decarbonization and the development of the European Green Deal"), NAS corresponding member Boris Basok ("Energy and environment pollution"), NAS corresponding member Petro Stryzhak ("Hydrogen production: prospects and limitations for industry decarbonization").

Also speaking at the session were: Ukraine Cabinet Minister Oleh Nemchinov, who read a greeting of the Prime Minister of Ukraine Denys Shmyhal; the Minister of Education and Science Serhiy Shkarlet, who stressed high relevance of the meeting's subject; Deputy Secretary of the National Security and Defense Council of Ukraine Oleksii Soloviov, who identified several promising areas of cooperation with scientists in neutralizing the challenges and hazards for the national security of Ukraine in the environmental sphere; the Head of the State Agency for Energy Efficiency and Energy Saving of Ukraine Valerii Bezus, who noted that the challenge of economy decarbonization is global, yet, for Ukraine this is a unique opportunity to develop its own economy relying on novel technologies. The session prepared an address to the Cabinet of Ministers of Ukraine containing specific proposals and recommendations regarding the prospects and ways of developing the model of low-carbon economy of Ukraine and the participation of the National Academy of Sciences of Ukraine in providing scientific support to this development.

On 17 March 2022, the Presidium of the NAS of Ukraine held its first session under martial law, where it considered the issues "On organizing the work of NAS institutions, organizations and enterprises under martial law" and "On the international activities of the NAS of Ukraine under martial law".

It was noted that in connection with the Russian armed aggression NAS Presidium took a number of prompt measures for ensuring the work of its institutions, organizations and enterprises, in particular, those related to the functioning of infrastructure facilities, transferring the employees to the remote mode of work, retaining all personnel and accounting documents. Besides, a commission on emergencies was set up.

Hostilities on the territory of Ukraine significantly complicated the functioning of NAS institutions, organizations and enterprises. Some of them turned out to be in the territories seized by Russian occupants. Some objects of scientific infrastructure were damaged, in particular, those of the institutes located in Kyiv, Kharkiv, Sumy, Mykolaiv and Dnipro. A considerable number of Academy's employees were forced to evacuate in search for a safe place to live.

In view of these circumstances, the Presidium of the NAS of Ukraine adopted the decision that charged the heads of NAS institutions, organizations and enterprises with ensuring the stable operation of organizations under martial law, appropriate registration of labor relations, preservation of especially valuable property, prompt evaluation of the losses it had suffered. Facilitation of the placement and accommodation of the NAS employees evacuated from war zones was recognized an important direction of work. The resolution stressed the necessity of reviewing research topics,

providing studies with realistic material, technical and personnel resources in accordance with their feasibility under martial law, as well as enhancing the scope of research aimed at scientific and technical provision of defense needs.

The consideration of the issue of NAS international activities under martial law stressed the unprecedented support to and solidarity with all the people of Ukraine and its scientific community, which were expressed by foreign and international scientific organizations as well as individual scientists from other countries. A number of international organizations curtailed their cooperation with russian state-run organizations and scientific teams as a sign of protest against the armed aggression of the russian federation. The global scientific community pooled their efforts to help the Ukrainian researchers who were forced to flee their homes and temporarily leave Ukraine. At the same time, the NAS Presidium noted that a broad international campaign in support of Ukrainian scientists by providing them with opportunities of employment in other countries in accordance with their professions implied a certain danger of a new wave of scientific emigration — the threat of increased departure abroad of talented young scientists.

As a result of discussing the issue, NAS Presidium adopted the resolution expressing profound gratitude to international organizations, academies of sciences, foreign scientific centers and individual scientists for standing with the NAS of Ukraine, its institutions and employees. The principal directions of Academy's activities under martial law were determined as well. First of all, those are the termination of any forms of NAS cooperation with russian scientific organizations and scientists, preparation of appeals to international scientific organizations to cancel the membership of russian scientific organizations and stop any cooperation with them. Among important areas of Academy's international activities, the resolution mentioned broad informing of foreign research communities about the full-scale hostilities, shelling of peaceful cities and towns, killing civilians, destroying industrial facilities and civil infrastructure. It also stressed the need for attracting the support of international and foreign organizations in the form of providing grants for research, funds for the maintenance and restoration of scientific infrastructure, humanitarian aid to Ukrainian scientists and their families.

On 15 June 2022, a session of the General Meeting of the National Academy of Sciences of Ukraine was held. It was concerned with the results of Academy's activities in 2021 — the first half of 2022 and the principal tasks of the next period.

Before the beginning of the event, the bust of academician Borys Paton, the long-term leader of the



Academician Anatoly Zagorodny, the President of the National Academy of Sciences of Ukraine, opens the session of the NAS General Meeting



Inauguration of the bust of Borys Paton, the long-term President of the National Academy of Sciences of Ukraine

National Academy of Sciences of Ukraine, was inaugurated in the Major Conference Hall of the NAS of Ukraine.

The session was opened by NAS academician Anatoly Zagorodny, the President of the National Academy of Sciences of Ukraine. The Minister of education and science Serhii Shkarlet, who attended the event, announced the greeting from the President of Ukraine Volodymyr Zelenskyy to the participants of the session.

The report of NAS academician Anatoly Zagorodny presented the results of world-class basic scientific research and important outcomes of innovative applied R&D that were obtained last year, and noted the status of the implementation of measures towards reforming the NAS of Ukraine. Anatoly Zagorodny informed about the current state of affairs in the National Academy of Sciences under martial law, about the challenges the Academy's scientific community was faced with during the full-scale russian aggression, and the losses inflicted on the Academy by the invaders.

After discussing the report, the General Meeting adopted a resolution on the top-priority tasks of the NAS of Ukraine for the next period. Among them were: retaining the human resources of the Academy, first of all its highly qualified personnel, its development after

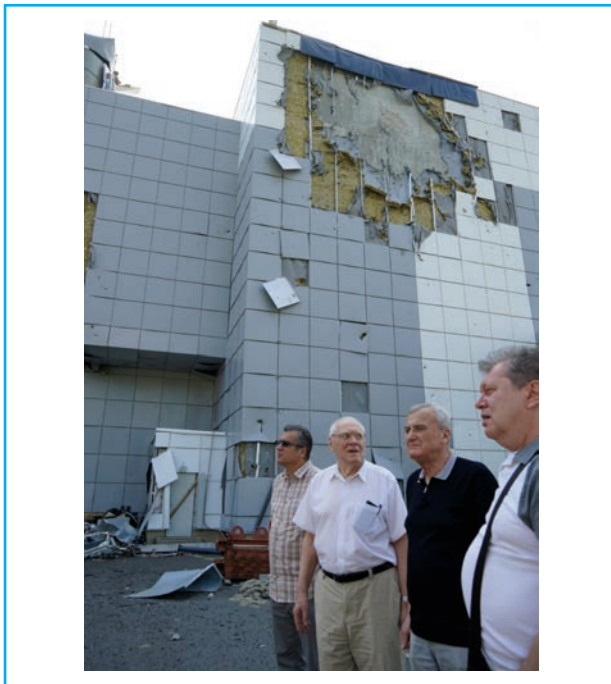

Academy leadership near the NSC “Kharkiv Institute of Physics and Technology”



Academy leadership at the Institute of Transport Systems and Technologies, Dnipro

the war, reconstruction of the destroyed and damaged infrastructure of scientific institutions, in particular, reconstructing and preparing the subcritical nuclear installation “Neutron Source” to pilot industrial exploitation, restoring the laboratory of the NAS Institute for Safety Problems of Nuclear Power Plants. It was considered necessary to expand the list of research subjects important for ensuring the security and defense of the state, the innovative development of strategic economy branches. The top priority of Academy’s activities should be efficient use of the opportunities of cooperation with international and foreign scientific organizations for maintaining and developing the scientific potential of the NAS of Ukraine, in particular, providing earmarked grants for conducting research at

Academy institutions, upgrading their laboratory equipment, and providing broader access for NAS scientists to international research infrastructure. The Academy must be actively involved in preparing proposals regarding the measures on the reconstruction and development of Ukraine, priority reforms, strategic initiatives, draft decisions, whose implementation would be necessary during the war and in the post-war period. Another important task would be to implement the recommendations for improving property accounting and the efficiency of its use that were given by Accounting Chamber according to the results of the audit of the efficiency of NAS management of state-owned objects.

Another issue of the General Meeting’s agenda was the exclusion from NAS membership of the people who had tarnished their high titles by supporting the Russian armed aggression against Ukraine. Secret voting resulted in the expulsion of 7 NAS members and 13 NAS foreign members from the Academy membership.

Visits of Academy leadership to the institutions of cities near the frontline.

In spite of extremely difficult wartime conditions, NAS institutions continued their work, contributing to the advancement of world science and scientific support to dealing with the challenges facing our country. The leadership of the Academy made sure of that when they visited institutions in Odesa, Kharkiv and Dnipro. The result of such trips in the “near-front regions”, meetings with scientific teams and heads of the regions was not merely on-spot familiarization with problems in institutions’ functioning, but also certain steps for resolving such problems, in particular, with the help of local authorities.

On 6—7 July 2022, the NAS President academician Anatoly Zagorodny and NAS Vice-President academician Viacheslav Bogdanov paid a working visit to Odesa, where they got detailed information on the work of the Southern Science Center (SSC) of the NAS of Ukraine and the MES of Ukraine and the Academy institutions in Odesa. In particular, during the meeting with the head of the NAS SSC academician Borys Burkinsky, director of the Institute for Market Problems and Economic-and-Ecological Research, and the associates of this institute the President of the NAS of Ukraine noted the work done by its scientists for program activities towards post-war restoration of Odesa region economy and set the task to further adjust the subjects of the research that would be aimed at Ukraine’s post-war economic renovation and development. Besides, there was a meeting of Academy leadership with the Head of Odesa Oblast Military Administration Maxim Marchenko and Odesa Mayor Gennadiy Trukhanov.

On 18—19 August 2022, Anatoly Zagorodny and Viacheslav Bogdanov visited the North-Eastern Science Center of the NAS of Ukraine and the MES of Ukraine

(Kharkiv). In the framework of the trip, they visited the National Science Center “Kharkiv Institute of Physics and Technology”, got acquainted with the working conditions at O.Ya. Usikov Institute for Radio Physics and Electronics, the Institute of Radio Astronomy, and B. Verkin Institute for Low Temperature Physics and Engineering, Scientific and Technological Complex “Institute for Single Crystals”, and A. Podgorny Institute of Mechanical Engineering Problems. During the meetings with institutes’ scientific teams, their activities under martial law alongside with the ways of dealing with important problems of their work were discussed. A conference with the directors of Kharkiv institutions of the NAS of Ukraine was held.

At the meeting with the Head of Kharkiv Oblast State War Administration Oleh Sinegubov, the President and the Vice-President of the NAS of Ukraine informed him on the most interesting achievements of Kharkiv scientists. They discussed urgent problems of scientific institutes’ work and the possibility of KhOSWA participating in the solution of those problems. The discussions were concerned, in particular, with the ways of reconstructing the damaged scientific facilities, providing heat, electricity and water supplies for institutions, as well as safeguarding them.

On 8—9 September, Anatoly Zagorodny and Viacheslav Bogdanov visited the Prydniprovskiy Science Center of the NAS of Ukraine and the MES of Ukraine (Dnipro). They discussed with the leadership of the Center the situation in the region, in particular, that with regard to the development of scientific research,

the cooperation of academy and sectoral science, interaction with higher education institutions and local self-government bodies.

NAS leadership visited M. Poliakov Institute of Geotechnical Mechanics and its Department for Mining Processes, as well as the State Enterprise ‘Specialized Design and Technological Office’ of M. Poliakov Institute of Geotechnical Mechanics, Z.I. Nekrasov Iron and Steel Institute, and the Institute of Transport Systems and Technologies of the NAS of Ukraine and the State Space Agency of Ukraine. During the meetings with the administration and the teams of region’s scientific institutions, the issues of work under martial law, financial provision, replenishing the institutions with young research personnel, organizing specialized scientific councils, the situation with defending PhD and doctor-of-science theses etc. were considered.

Important events in the framework of this trip were visits to the enterprises of the rocket and space industry of Ukraine — the State Enterprise “M.K. Yangel Design Bureau ‘Pivdenne’” and the State Enterprise “O.M. Markarov Industrial Association ‘Pivdenny Machine-Building Plant’”. The NAS delegation was shown the production facilities of those enterprises and familiarized with the main directions of their work in today’s conditions. Besides, the results of cooperation under the General Agreement on the S&T cooperation between the National Academy of Sciences of Ukraine and the State Enterprise “M.K. Yangel Design Bureau ‘Pivdenne’” in developing rocket and space technology were discussed.

LOSSES CAUSED BY RUSSIAN AGGRESSION

After 24 February 2022, the scientific infrastructure of the Academy suffered huge losses due to barbaric massive air strikes, missile attacks and artillery shelling of peaceful Ukrainian cities and towns. The buildings of many scientific institutions and scientific infrastructure facilities in Kyiv, Dnipro, Kharkiv, Sumy, Mykolaiv were damaged.

The heaviest damage was caused to Kharkiv Academy institutes of Single Crystals, Radio Physics and Electronics, Kharkiv Institute of Physics and Technology, Institute for Low Temperature Physics and Technology. Seriously damaged was the unique nuclear installation 'Neutron source based on the subcritical assembly driven by a linear electron accelerator'. It was built with the US support and, in terms of its parameters, it had no peers in the world. There were plans to set up an international research center on its basis. Seriously damaged was the world-largest UTR-2 decameter radio telescope of the Institute of Radio Astronomy, whose antenna field, situated in Kharkiv Oblast, was under occupation for a long time. S.Ya. Braude Radio Astronomy Observatory with its GURT radio telescope was plundered and destroyed during the occupation.

The equipment was destroyed and laboratories were ruined at the Institute for Safety Problems of Nuclear Power Plants, which carries out scientific support to and status control of the "Shelter" facility in Chernobyl. Geomagnetic laboratory "Kyiv" of S.I. Subbotin Institute of Geophysics of the NAS of Ukraine, which is located in Dymer town (Kyiv Oblast) also suffered under Russian occupation. Invaders caused significant damage to the buildings of the Institute of Pulse Processes and Technologies in Mykolaiv and V. Bakul Institute for Superhard Materials in Kyiv. The National Museum of Natural History, T. Shevchenko Institute of Literature, M.S. Hrushevsky Institute of Archeography and Source Studies, the Manuscript Institute of V.I. Vernadsky Library of Ukraine, H.S. Skovoroda Institute of Philosophy, M.H. Kholodny Institute of Botany, I.I. Schmalhausen Institute of Zoology, the Institute of Renewable Energy and the buildings of Academy Presidium and Major Conference Hall suffered from missile attacks on the Ukrainian capital.

Several Academy institutions still are in the occupied territory: Luhansk Nature Reserve, the Black Sea Bio-

sphere Reserve, and a part of Ukrainian Steppe Nature Reserve.

In total, nearly 220 objects of the NAS property complex (buildings, structures etc.), with the total book value of almost € 400 million, were damaged or completely destroyed as a result of the Russian aggression. Nearly 630 pieces of scientific instruments, office equipment etc. of the total book value of over € 200 million were damaged, completely destroyed or looted.

The Russian invasion deprived many of our scientists of the possibility to work at their institutes and forced them to temporarily change their place of residence. In particular, over 370 scientists are currently living in Germany, 270 — in Poland, nearly 100 — in France, 68 — in the USA, 66 — in the Czech Republic. Over 900 employees of the Academy moved to other regions of Ukraine. All in all, more than 14% of the total number of our research associates left their places of permanent residence.

Regrettably, there are human losses. In the very first days of the war, during evacuation, the occupants killed NAS corresponding member Vasyl Kladko, deputy director of V.Ye. Lashkaryov Institute of Semiconductor Physics. In early April, Oleh Kozak, the main bibliographer of T. Shevchenko Institute of Literature, died during evacuation from an occupied village in Kyiv Oblast. Enemy shelling killed Volodymyr Begeniov, an employee of I.M. Frantsevich Institute for Problems of Materials Science, in his own yard in Kyiv Oblast. Kostiantyn Miagkokhlib, senior researcher of the reliability and dynamic strength department of A. Pidhornyi Institute of Mechanical Engineering Problems, died in shelling in Kharkiv.



S&T complex "Institute for Single Crystals" of the NAS of Ukraine after shelling, Kharkiv

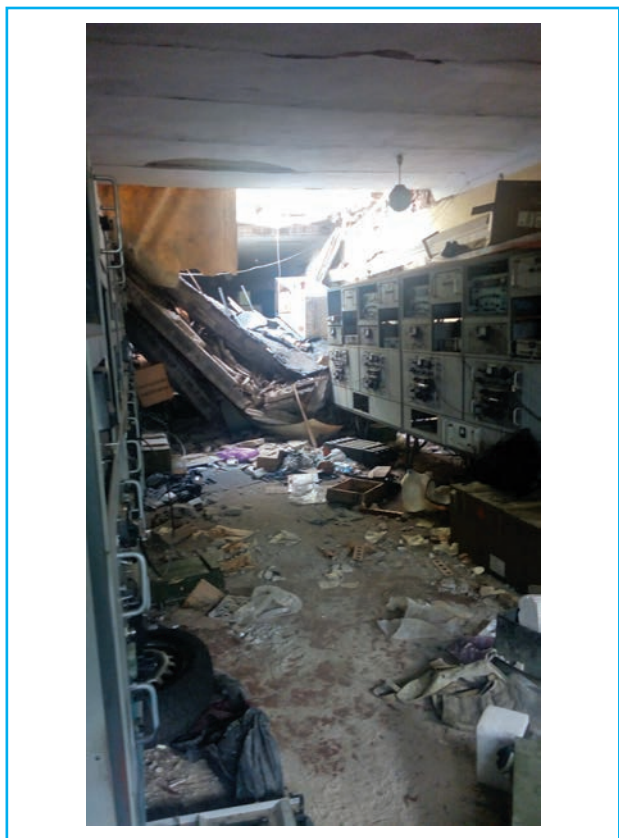

UTR-2 radio telescope of the NAS Radio Astronomy Institute after occupation, Kharkiv Oblast

There were combat losses as well. In June, in a battle near Kharkiv, Andriy Lytovchenko, an employee of Bogolyubov Institute for Theoretical Physics, was killed. He served as a volunteer in the 241st brigade of the Armed Forces of Ukraine, was the leader of the first platoon of "Chornyi Voron" ('Black Raven') rifle company. The Russian aggression took the life of Nazar Bezrukavyy, research associate of the Institute of Technical Mechanics. The fate of a senior researcher of the Institute of Applied Mathematics and Mechanics Mykhailo Voitivych, who went missing in March 2022, remains unknown. Volodymyr Makogon, a doctoral student of the Institute of Geological Sciences, was killed in Bakhmut at the end of 2022. Defending Ukraine, two employees of the Institute of Molecular Biology and Genetics — head engineer Maxim Pavlenko and young scientist Vasyl Vdovin — died in battles against Russian invaders. Andriy Kravchenko, research associate of Chuyko Institute of Surface Chemistry, died while performing a combat mission in Brovary district. Bizhan Sharo-



Building of V. Bakul Institute for Superhard Materials after missile attack, Kyiv

pov, a young scientist of Bogomoletz Institute of Physiology, fell in the battle for Izium.

A deep bow, eternal memory and eternal glory to the heroes who died for Ukraine!

Among the losses caused by Russia's armed aggression is a substantial decrease of NAS funding. The Law of Ukraine "On the 2022 State Budget of Ukraine" had allocated € 6.163 bn from the budget general fund for financing the National Academy of Sciences of Ukraine. However, due to channeling all resources into the sphere of defense, by Government decisions that funding was reduced by 17.1%.

Due to limited funding, the Academy had to curtail research in many scientific directions. Funding was stopped for several targeted programs of scientific research, viz.: "S&T problems of monitoring, assessing and extending the life of structures, equipment and buildings of long-term operation (Resource-3)", "Prospective basic research and innovative developments of nanomaterials and nanotechnologies for industry, medicine and agriculture", "Critical and strategic mineral resources of Ukraine under globalization and climate change", "Novel functional substances and materials of chemical industry", "Genomic, molecular and cellular fundamentals of developing innovative biotechnologies" etc. Besides, the initiation of new targeted programs and procurement of advanced scientific equipment were suspended.

The average monthly salaries of NAS employees also dropped. In 2022, the monthly payment was € 12013.7, which is less than in 2021, and substantially less than the average salary in the industry and economy of Ukraine. The average coefficient of working hours regime in 2022 dropped to 0.85 (10.2 months).

RESEARCH ACHIEVEMENTS. NATURAL AND ENGINEERING SCIENCES

James Webb space telescope observations of galaxies in the epoch of Universe reionization

One of the most relevant problems of present-day cosmology is to determine the main sources of ionization emission and their properties in the epoch of the latest phase transition of the Universe — its reionization. In that period the age of the Universe was from 400 m to 1 bn since the moment of Big Bang. Theoretical and observational data show that reionization took place, mainly, under the action of dwarf galaxies with active



James Webb space telescope

star formation. Until recently, the properties of these galaxies were unknown due to their low brightness and huge distance from the Earth, which amounts to 13 bn light years.

The situation changed radically in 2022, when James Webb space telescope with the mirror of 6 meters in diameter was launched into a heliocentric orbit. This telescope has high spatial resolution and is optimized for working in the infrared range, which permits the registration of weak galaxies emission in the epoch of reionization, which due to large redshift is displaced to the infrared range.

The international team of scientists from Ukraine (Bogolyubov Institute for Theoretical Physics of the NAS of Ukraine), Switzerland, France, Denmark and the United States of America) used the first high-quality observations of galaxies in the reionization epoch, conducted in July 2022, and were the first to determine their chemical composition.

It was revealed that the ratios of line intensities in the spectra of galaxies in the epoch of reionization agrees

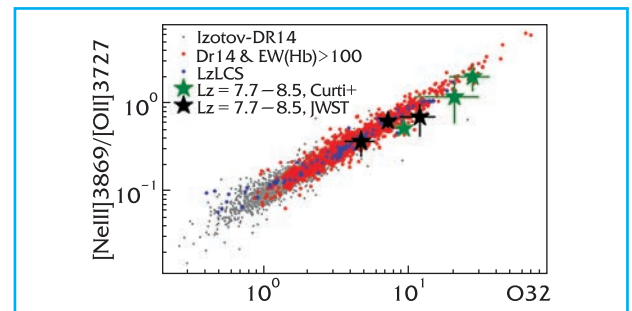

Example of a comparative diagram of the distributions of intensity ratios for some strong emission lines in galaxy spectra in the reionization epoch (capital symbols) and dwarf galaxies with active star formation in the current epoch (lowercase symbols). The ratios of emission lines intensities $[O III] 5007 / [O III] 3727$ is denoted as O32

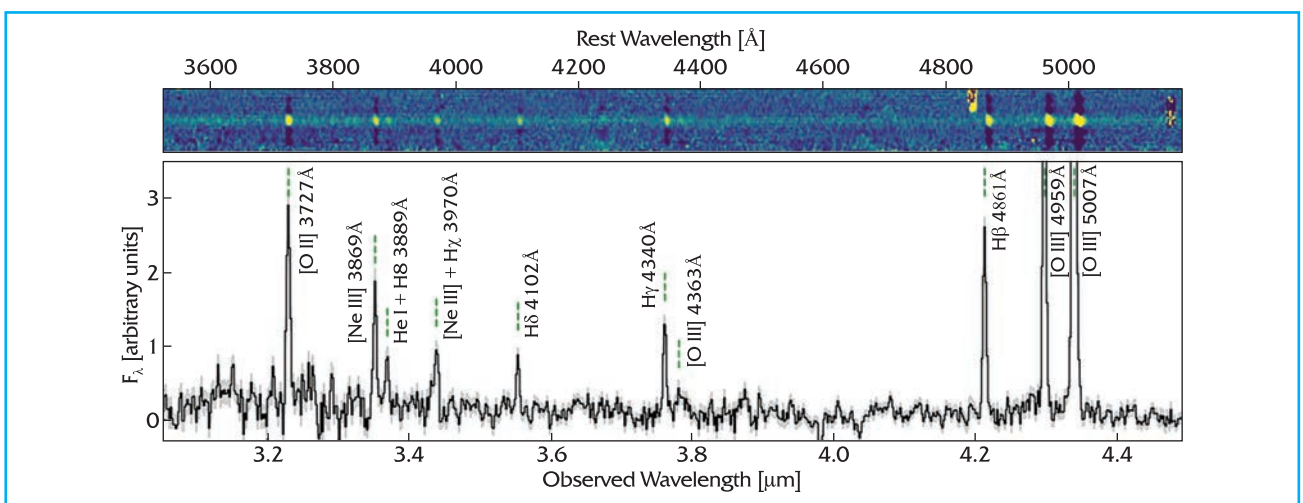

Spectrum of a galaxy from the reionization epoch

well with the respective data in the current epoch. It was also discovered that the chemical composition of galaxies in the epoch of reionization is similar to that of today's dwarf galaxies with active star formation.

This shows that the enrichment of galaxy's interstellar medium with the products of stellar nucleosynthesis happens very fast and the galaxy "does not remember" the initial conditions of its formation. The similarity of galaxy properties in the current epoch and those in the epoch of reionization provides an opportunity for using the results of exploring the closer galaxies studied earlier for the research of galaxies in the early Universe.

D. Schaerer, R. Marques-Chaves, L. Barrufet, P. Oesch, Y. Izotov, R. Naidu, N. Guseva, G. Bramme

Interaction of low-frequency waves with inhomogeneous atmospheric currents

The Space Research Institute of the NAS of Ukraine and the State Space Agency of Ukraine developed new theoretical models describing the propagation of low-frequency waves in the atmospheres of the Earth and the Sun, which take into account the effect of inhomogeneous background waves. It is well-known that the properties of acoustic-gravity waves (AGW) in the atmosphere can depend on the properties of propagation medium to a greater extent than on the disturbance sources themselves. Provided inhomogeneous atmospheric currents are present, significant deviations of AGW characteristics from the theoretical ones are observed. This considerably complicates experimental diagnostics of the waves and the search for the relationships with their potential sources.

The analysis of the measurements made by Dynamics Explorer 2 satellite shows a close relationship between atmospheric wave disturbances in the polar thermosphere and wind circulation. According to satellite data, acoustic-gravity waves of large amplitudes are regularly observed in the regions where powerful wind

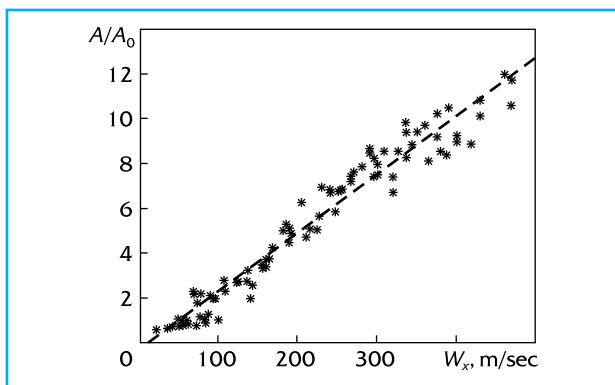

Dependence of acoustic-gravity wave amplitudes on headwind speed. Asterisks are experimental values, the dashed line shows theoretical dependence

systems are formed. The waves propagate mainly against the wind, and their amplitude is proportional to wind speed.

The results obtained permit the peculiarities of wave field formation in the polar thermosphere to be explained as a consequence of wind filtering of the primary wave spectrum generated by different sources. The wind-driven AGW are quickly attenuated, while waves moving against the wind are selectively amplified. With an increase in geomagnetic activity, the velocities of polar vortices rise, which is also accompanied by a rise in AGW amplitudes in these regions. Hence, these waves play an important role in the energy balance of the polar atmosphere since they redistribute the energy of horizontal wind currents in the vertical direction.

O. Chermnykh, A. Fedorenko, E. Kryuchkov, I. Zhuk

Physics-informed neural networks for meteorology

The use of deep neural networks has become common in many fields of science, in particular, for solving applied problems, the most popular ones being images classification and computer vision, natural language processing and reinforcement learning. The rise of in-depth learning popularity also occurred in geophysical hydrodynamics. Numerous research teams worldwide successfully use deep neural networks for tasks dealing with weather forecasting and analysis. However, these studies largely ignore the fact that in meteorology, like in other natural sciences, data evolution is adequately described by well-known systems of differential equations.

In 2019, American scientists M. Raissi, P. Perdikaris and G. Karniadakis developed a novel approach to solving differential equations, based on special deep neural networks that are referred to as physics-informed neural networks. Such neural networks are trained, adhering to the given laws of physics formulated in terms of differential equations with certain initial and boundary conditions. This approach to integrating differen-

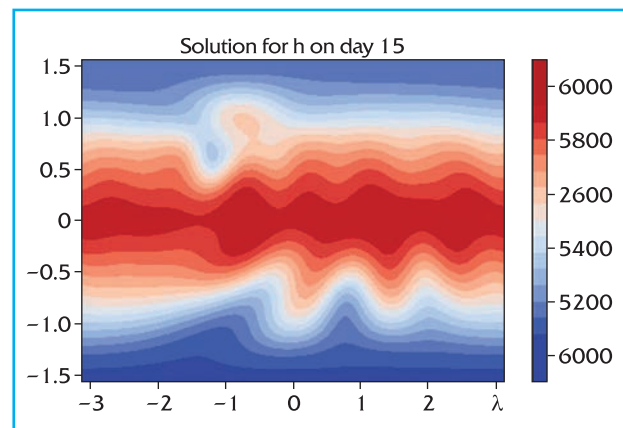

Modeling of zonal flow over an isolated mountain

tial equations can be an alternative to traditional numerical approaches.

Scientists of the NAS Institute of Mathematics, in collaboration with researchers of Memorial University of Newfoundland (Canada), extended the abovementioned studies and used physics-informed neural networks in solving the shallow-water equations on a sphere in the context of meteorology. They developed a simple multi-model approach for the case of long time intervals. Within this approach, a single neural network for the entire integration interval is substituted with a sequence of neural networks that are subject to sequential training. The use of boundary value loss was avoided by coding boundary conditions in a special layer of the neural network. That considerably increased training efficiency and, accordingly, improved the precision of calculations. The potential of the method were demonstrated by solving the most famous test cases in

meteorology, in particular, modeling of a global steady-state nonlinear zonal geostrophic flow, the zonal flow over an isolated mountain and Rossby–Gaurwitz waves.

The results of the work were published in the prestigious international edition *Journal of Computational Physics* (Bihlo A., Popovych R.O. Physics-informed neural networks for the shallow-water equations on the sphere, *J. Comp. Phys.* 456 (2022), 111024, 18 pp., arXiv:2104.00615. <https://doi.org/10.1016/j.jcp.2022.111024>).

R. Popovych

Nanoscale particles localization in optical microscopy

Advanced optical microscopy of the 21st century permits obtaining images of the objects whose size may be smaller than the wavelength of light although quite recently they were unobservable by optical methods. The outstanding value of these achievements was

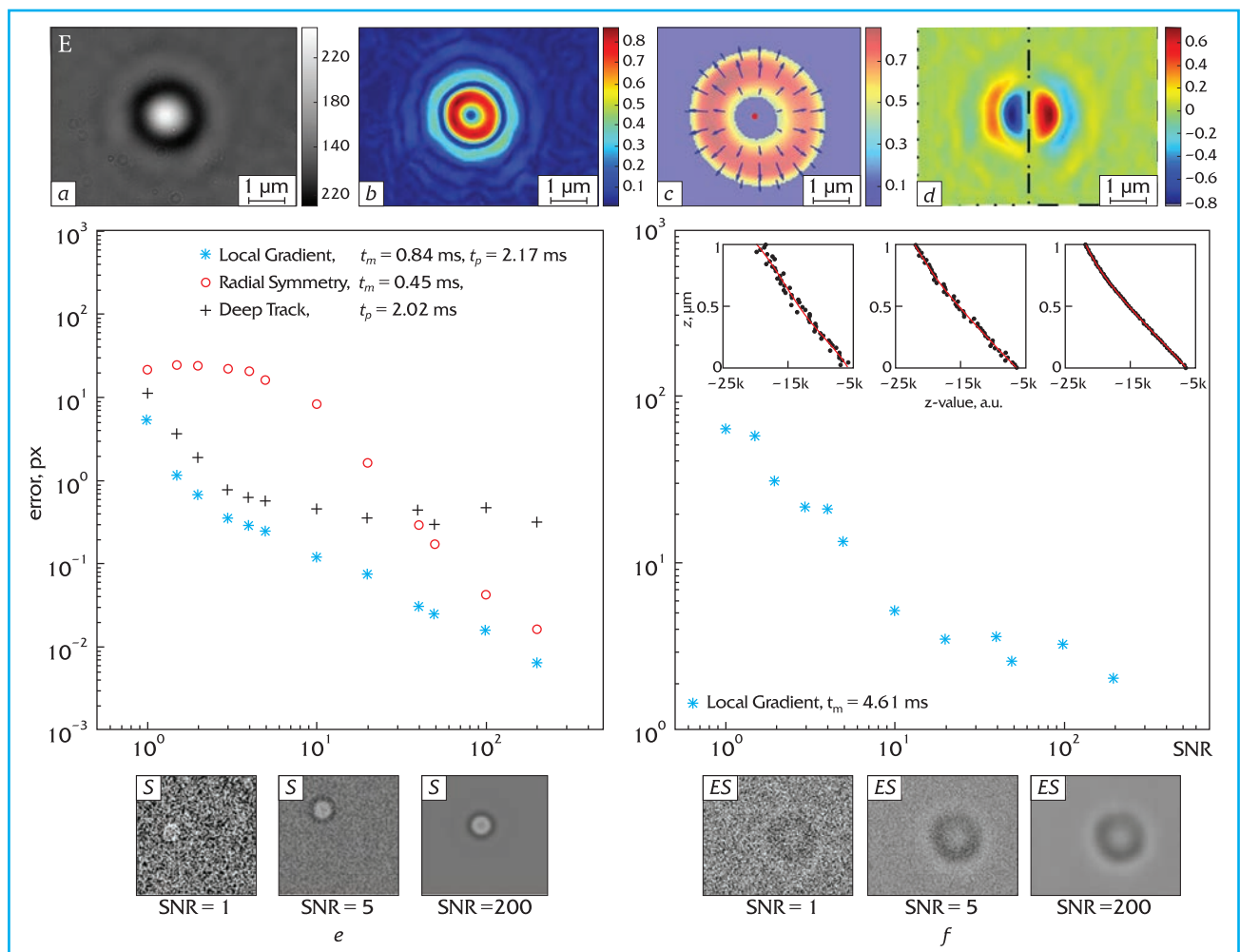

Particle localization by local gradient method: (a) image of a 0.9 μm silica particle; (b) values of local gradients; (c) local gradient vectors for individual pixels. Position of the particle (the red spot) is determined as the intersection of gradient vectors; (d) the principle of calculating coordinate z; (e) comparison of the accuracies and execution times of XY-localization algorithms and various signal-to-noise ratios. t_m and t_p are average execution times in Matlab and Python; (f) algorithm accuracy and execution time for z-localization; The bottom part of the figure shows test images for neural network training (S – computer simulation, ES – experiment, for signal-to-noise 1, 5, 200)

recognized by awarding the 2014 Nobel Prize to their authors, as before them it had been believed that the visible sizes of sub-wavelength object images (micro- and nanoparticles of various compositions and shapes, microorganisms, proteins and vesicles in cells), some fluorophores — molecules or their parts, chemical functional groups able to fluoresce) impose fundamental restrictions on the precision of object's spatial localization, limiting it by the wavelength of light.

However, precise localization of micro- and nanoparticles plays an important role in physical and biological studies, in particular, in nanomechanical measurements carried out with optical and magnetic tweezers or atomic force microscopes in the experiments demanding nanometer or sub-nanometer stability of an optical microscope.

As of today, the most common way of localizing an individual nanoparticle is to use methods in which the difference of light intensity between neighboring pixels is calculated for determining the directions and values of intensity gradients, while particle position is determined as the intersection of gradient lines. These methods were extended to the 3D localization of fluorescent particles by using astigmatism-based microscopy to obtain an image with longitudinal gradients. A new step in developing these methods is to use neural networks for localizing particles of various types, shapes and sizes.

The research conducted by scientists of the NAS Institute of Physics in collaboration with colleagues from the University of Florence and the European Laboratory for Non-Linear Spectroscopy, using the calculation of local gradients of image intensity, proposes a set of computational instruments for the 3D localization of both fluorescent and unlabeled particles. The software is mainly intended for the systems of active stabilization in microscopy and includes parameters easily adaptable to specific conditions. The calculations are performed in a short period of time and provide accurate results, with a low level of signal-to-noise ratio. The work of the algorithm of local gradient efficiency was tested and its performance demonstrated for 3D localization of particles in brightfield and darkfield imaging and of fluorescent particles in astigmatism-based microscopy.

The method developed is superior to the most advanced methods of localization under high noise levels and is capable of localizing nano- and microparticles in 3D space with nanometer accuracy and the computation time of milliseconds. The localization of the fixed particle as a reference point and the generation of feedback demonstrated its applicability for active drift correction in sensitive nanomechanical measurements, such as optical trapping and images with superhigh resolution. Multi-platform package of open-source software that contains a set of instruments for calculating the local gradient in the bright-

field, dark-field and fluorescent microscopy is available to be used by scientific community.

O. Perederiy, A. Kashchuk, A. Negriyko

Superparamagnetic coordination polymers with adaptive behavior towards external factors

Scientists of the NAS Institute of Macromolecular Chemistry develop new approaches to producing analogs of metal-organic frameworks (MOF) that are to be used as ligands instead of low molecular weight compounds of functionalized oligomers having varied molecular architecture. The porosity of such analogs is provided due to globular structure of output oligomers and the presence of internal pores in their composition. The use of these oligomers also provides the possibility of forming self-ordered structures. In particular, a method was developed for synthesizing ion-coordination network polymers (*OSS-polymer-Me*) whose ligands are oligomeric silsesquioxanes (*OSS*) of the general formula $(R\text{SiO}_{1.5})_n$. They contain in their structures a nano-sized (~ 0.5 nm) inorganic silsesquioxane core $(\text{SiO}_{1.5})_n$ ($n \sim 16$) and organic substitutes *R* of two types: alkylurethane fragments and carboxyl groups. The choice of Co^{2+} and Ni^{2+} metal ions was made in view of the prospect of providing *OSS-polymer-Me* with magnetic properties. With reliance on experimental data, a model of *OSS-polymer-Me* supramolecular structure was proposed. According to it, metal ions are localized in the nodes of irregular network and link *OSS* molecules into a single system, which leads to an ordered localization of inorganic cores that can be described as a paracrystalline order.

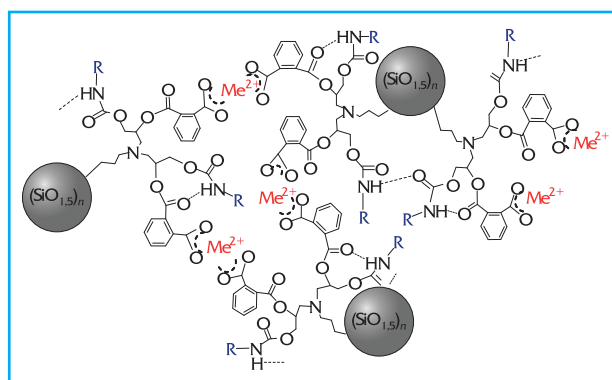

$R = \text{C}_{18}\text{H}_{37}$ alkylurethane fragments, $\text{Me}^{2+} = \text{Co}^{2+}, \text{Ni}^{2+}$ metal ions



3D image of
*OSS-C₁₈H₃₇-25-COOH-
75-Co*, obtained by X-ray
projection microscopy

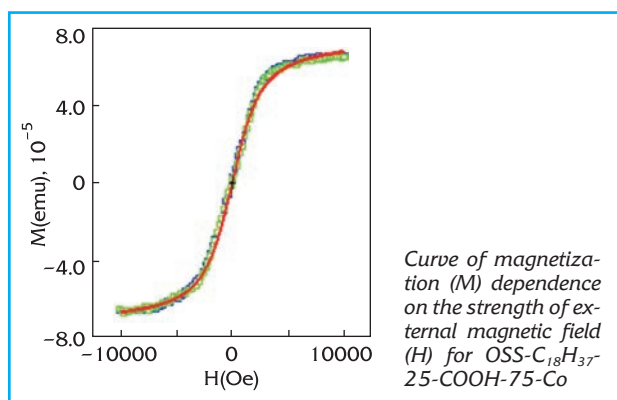

The molecular architecture of output OSS provides porous structure of the compounds obtained.

The dependence of OSS-polymer-Me magnetization on the strength of external magnetic field is described by Langevin function, which gives evidence of their paramagnetic properties. It was found that the average magnetic moment of OSS-polymer-Me is several thousand times higher than that of the individual ions of respective metals due to cooperative interaction of the latter as parts of the supramolecular structure formed, i.e., the synthesized compounds are superparamagnetics at room temperature.

The systems obtained are sensitive to the action of magnetic field and temperature. The recovery of their structure after thermal influence takes much time — from one to several months. However, the action of an external magnetic field can significantly accelerate this process (to several minutes).

The coordination polymers developed are promising as “intelligent” materials that are able to change their structure in response to the action of temperature and external magnetic field and function as sorbents, catalysts etc.

V. Shevchenko, M. Gumenna, O. Stryutsky

Identification of a new gene whose mutations cause gonadogenesis disorders

Scientists of the NAS Institute of Molecular Biology and Genetics jointly with their Spanish and Swiss colleagues investigated molecular genetic mechanisms of developmental disorders and sex differentiation, and carried out the whole exome sequencing and analysis of genome coding sequence of a patient with 46,XY genotype and *primary hypogonadism, ovotestis, gonad dysgenesis* diagnosis, as well as that of his healthy parents.

Among 46435 SNV or minor indel variants, 9 candidate genes were identified as rare potentially pathogenic. However, according to the results of bioinformatics analysis, only the transition in gene *STARDB8* NM_001142503.2

c.2659 C>T (*p.Arg807Cys*) (rs766188656) — hemizygous missense mutation inherited from the heterozygous mother — in its characteristics matched the potentially pathogenic variant (*Mutation Tester: disease causing, 0.773; PolyPhen: possibly damaging, 0.513*). The presence of this mononucleotide substitution was validated via Sanger sequencing.

It is important to note that neither the abovementioned variant, nor *STARDB8* gene had been described earlier as factors of any disease.

Modeling of *STARDB8* protein molecule was carried out and the dynamics of its mutant and normal variants were compared. It was found that domain *Rho GTPase* retained its spiral bunch structure, while *StarT* domain, due to the disappearance of h-bonds formed by arginine, completely changed the structure of the spiral containing *R807C*, which caused the displacement and destruction of steroid binding site.

It was proven experimentally that it is *StarT* domain of *Cv-c*, *STARDB8* orthologs that is responsible for gonadogenesis and, in particular, for the formation of testicle tissue structures during fetal development. Researchers discovered a new gene, which, if inherited by son from his mother, leads to developmental disorder of

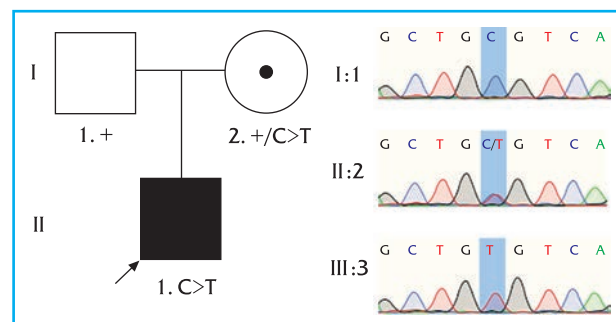

Genealogy and chromatogram of Sanger sequencing of UKR05 patient and his healthy parents

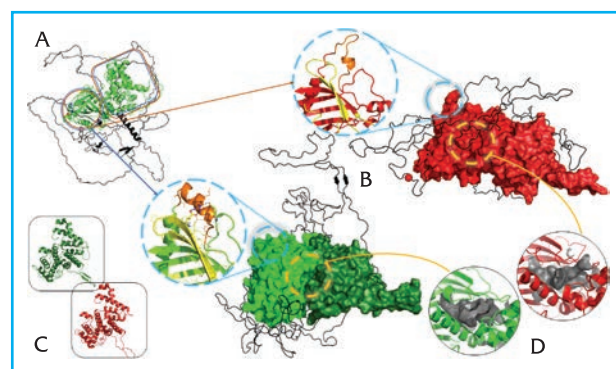

A — initial state for WT and mutant full *StarDB8* length, predicted with AlphaFold 2.0; B — black bands for disorderly areas covering the red surface of the mutant shape and the absence of such shielding in green WT protein; C — structure stability of GTPase Rho domain and spiral unfolding as a result of mutation causing displacement of β -leaflet and closure of steroid-specific tunnel in *StarT* domain; D — destruction of the steroid-binding site

male genitals, infertility and causes a high risk of malignant tumors of the reproductive system.

This discovery is promising for diagnosing developmental disorders and differentiation of reproductive system organs in patients, as well as the search for the ways of their treatment.

L. Livshits, D. Sirokha, O. Rayevsky

Mechanical-and-mathematical model for investigating mechanically stressed osseointegration phase in implant – bone system after dental implantation

Scientists of S.P. Timoshenko Institute of Mechanics in cooperation with scientists of Bogomolets National Medical University developed a mathematical-and-mechanical model of masticatory load transfer via implants to the surrounding bone tissue whose structure is inhomogeneous. With reliance on discrete-continual and discrete approaches, numerical analysis of the stress-strain state in the implant—bone system was carried out, with taking into account implant shapes and structures, as well as bone tissue volume and biomechanical structure. A biomechanical model of the destruction of the implant—bone and tooth—bone systems after orthopedic and orthodontic treatment was built.

Load distribution over the threads of the implant connection to the bone was investigated. Threaded connection was modeled by a rod connection in which functional tensile axial load from the implant rod was transferred to the bone rod via threads.

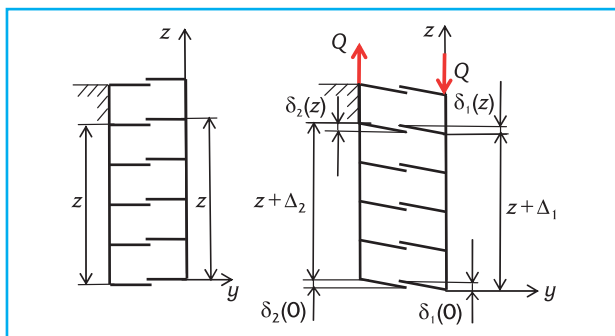
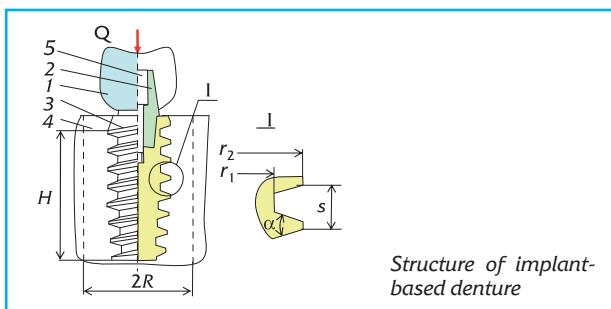

Computational scheme of the implant-bone threaded connection before (left) and after loading

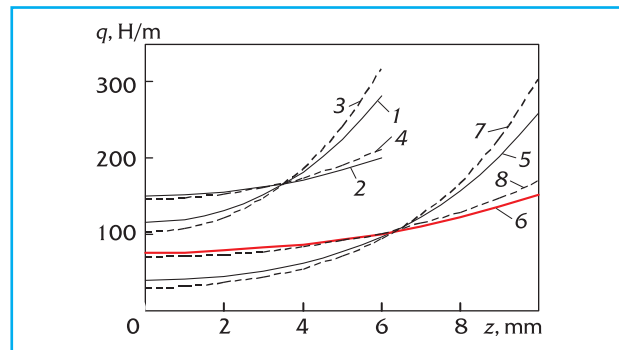

The plot of changing the intensity of axial force distribution along the threaded connection, depending on the thread length for different variants (1 – 8) of the implant-bone system, depending on the thread pitch and bone material

Experimental studies of the physico-mechanical characteristics of dental implants of various shapes and for varied purposes proved that the determining factor in using the specimens studied was the composition of the material they are produced of and, in the case of an alloy, the distribution of alloy elements over implant surfaces, which is important in view of possible oxidation of these elements in the electrolytes of a live organism and their surface porosity. A more uniform element distribution over the surface and its lower porosity were found to have a positive effect on the corrosion resistance of the specimens.

Research into determining the resistance reactions of edentulous spaces located posterior to the remaining natural teeth of removable partial dentures with rigid and flexible attachments was carried out. To investigate the stressed state of the denture—jaw system, a spatial model was used. It was shown that support reactions of removable partial dentures with stiff attachments are distributed more evenly than in the similar dentures with flexible attachments.

V. Bogdanov, O. Grigorenko, V. Malanchuk, M. Tormachov

Creation of gluten-free wheat lines

The demand for hypoallergenic foodstuffs is constantly growing. Ever more often they are labelled as free from gluten. It is the creation of gluten-free wheat varieties that scientists of the State Institution “NAS Institute of Food Biotechnology and Genomics” are working at. In particular, they have selected winter wheat lines with the absent synthesis of omega-gliadins, which are strong allergens capable of causing anaphylactic shock in adults, dermatitis in children and other types of allergies after consuming wheat products. Seeds of wheat lines produced by crossing *Odeska chervonokolosa* × B16, with null alleles at gliadin *Gli-B1* and *Gli-D1* loci, and with favorable alleles of *Glu-1* loci (with the combination of *Glu-A1b*, *Glu-B1a1*, *GluD1d* alleles) was transferred to Poltava State Agrarian University for further breeding

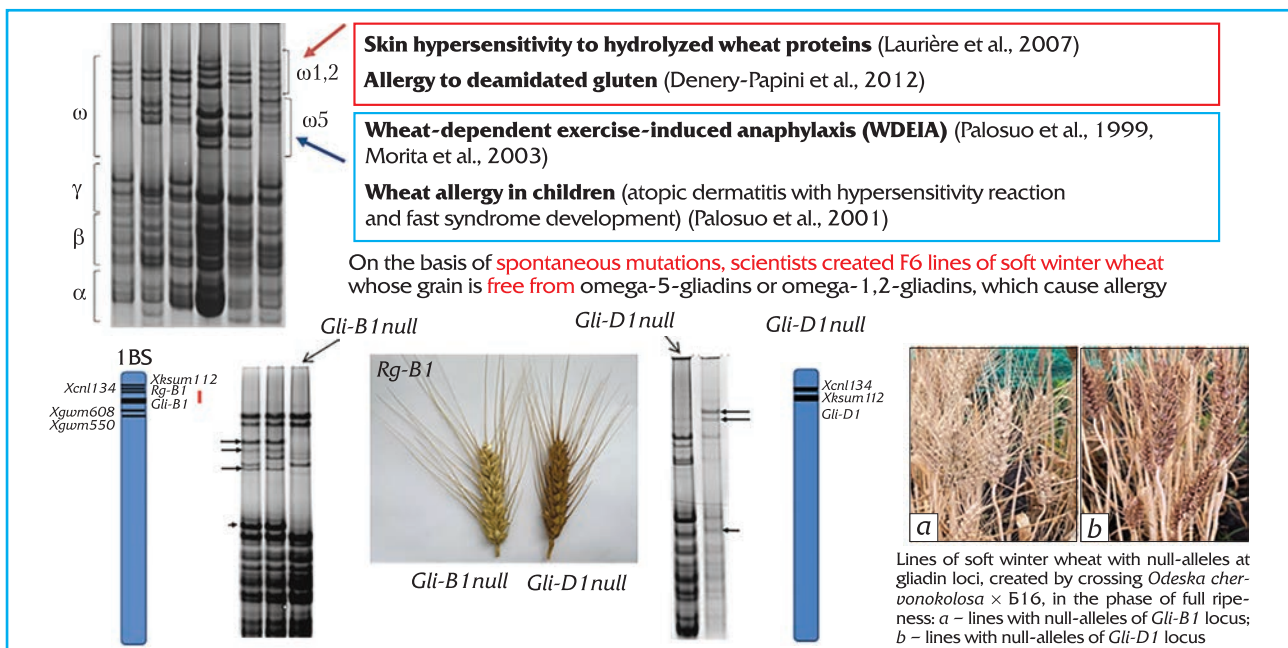

Creation of wheat lines free from omega-gliadins, which cause allergy

work and to V.Ya. Yuriev Crop Production Institute for creating hypoallergenic varieties.

Ya. Blume, N. Kozub, Ya. Pirko, S. Spivak

Innovations providing a boost to grain production in Ukraine

Scientists of the NAS Institute of Plant Physiology and Genetics were the first, to initiate pioneering scientific trends in breeding cereal crops varieties with high grain quality and nutritional value, and to develop innovative cultivars. Creating such varieties makes it possible to radically improve the nutritional value of the grain of wheat and hullless barley. The results of these scientific developments are already being implemented in new functional foodstuffs that had not been produced before.

New fundamental approaches to breeding new, high-yielding, high-quality ecologically adaptable and disease-resistant wheat varieties were developed. In particular, it was proven that *Gpc-B1* gene introgressed into the genome of cultivated wheat from wild emmer,

controls the marker of physiological aging of wheat plants and, due to nitrogen remobilization from vegetative organs to reproductive ones, is able to increase significantly protein content in the grain without a noticeable drop in the yield. Promising breeding material containing *Gpc-B1* gene was produced; it was not inferior in grain yield to the standard cultivar and had improved characteristics both in terms of grain protein content and its quality. The presence of this gene in the grain positively correlates with the key characteristics of wheat flour baking quality, such as flour "strength" and dough elasticity index.

It is important to note that the Institute, even under the extremely difficult conditions of martial law, provided scientific support to cultivating novel winter wheat varieties of its own breeding on the area of about 2 million hectares. The gross grain harvest of these varieties fully satisfies Ukraine's need for food wheat and is a substantial contribution to the country's food security.

V. Morhun, O. Rybalka, V. Schwartzau, B. Morgun, V. Orekhivskyi, D. Kononov

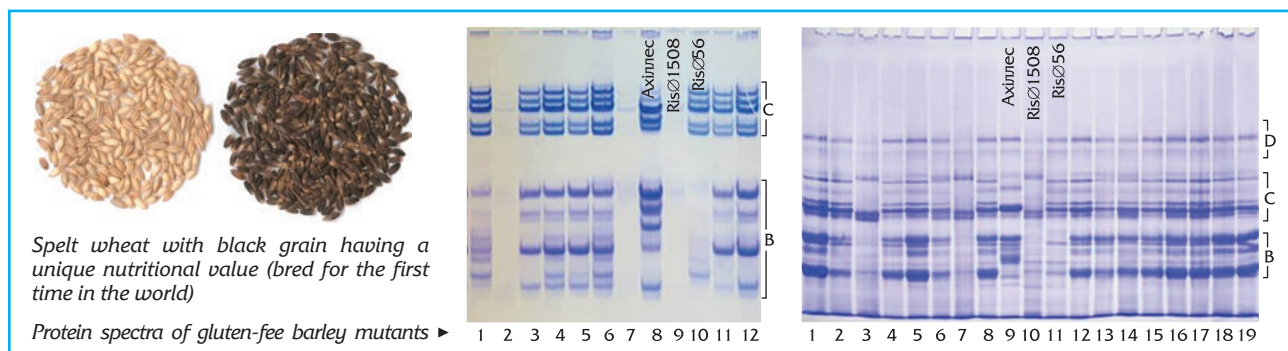

SCIENTIFIC ACHIEVEMENTS. SOCIAL SCIENCES AND HUMANITIES

Scholars of the NAS Section of Social Sciences and Humanities (SSSH) conducted a considerable amount of research addressing economics, socio-political and cultural development of Ukrainian society.

The full-scale war of Russia against Ukraine, which was started on 24 February 2022, necessitated cardinal changes in the research plans of the SSSH institutions. They envisage focusing on certain problematic areas and discipline spheres related to studying current military and political realities and their influence on Ukrainian society.

Economics scientists of the Academy prepared a multi-disciplinary analytical study **“Post-war revival of Ukraine. Vision of the NAS Department of Economics”**, where they analyzed key opportunities, threats and challenges to the future, determined the directions of Ukraine revival and proposed a vision of further actions. This was a collaborative work of all research institutions of the NAS Department of Economics: Ptoukha Institute for Demography and Social Studies, the Institute for Economics and Forecasting, Research Center for Industrial Problems of Development, the Institute of Environmental Economics and Sustainable Development, the Institute for Market Problems and Economic-and-ecological Research, M.I. Dolishniy Institute of Regional Research, V.K. Mamutov Institute of Economic and Legal Research, the Institute of Industrial Economics, Zakarpattia Regional Centre for Socio-Economic and Humanities Research.

Scientists outlined nine directions of the future revival of Ukraine: ensuring the national security and defense; development of critical infrastructure, development of competitive sustainable economy; integrated development of territories; transformation of labor markets; environment restoration; combining the strict adherence to laws with revolutionary changes; demographic revival; establishment of a new quality of life.

The vision of the post-war revival of Ukraine conceives the formation of modern democratic society with human-centered economy that would be resistant to risks. The basis of the post-war revival of Ukraine should be a new social contract aimed at the most equitable distribution of economic growth results, re-

duction of inequality and population poverty, achievement of the East-European parameters of the quality of life.

Institutional instruments would minimize personal involvement in management processes. Rational placement of infrastructure facilities over the territory of the country would protect the population and business as much as possible from the risks of being situated close to the borders with the aggressive neighbor. A high level of defense complex development would guarantee the ability to repulse the aggressor. Transformation of the economy would create the basis for Ukraine involvement in the global chains with high added value, the appropriate competitiveness of products, a balance between its own provision of internal needs and international cooperation. A rational system of natural resources management would not merely satisfy current needs but also ensure environment restoration. The changes would result in overcoming the catastrophic demographic impacts of the armed aggression, although population decline and the deformation of its sex-age structure are inevitable.

The leader of the author's team is E. Libanova

The State Institution ‘The Institute of Economics and Forecasting of the NAS of Ukraine’ prepared the scientific paper **“Restoring and reconstructing the post-war economy of Ukraine”**. It presents the conceptual and practical plan of the post-war reconstructive revival of Ukraine’s economy, whose implementation permits the unification of varied actions of economic entities and state authorities into a purposeful process of the nationally rooted sustainable technological and socio-economic development, which would allow the overcoming of Ukrainian economy fragmentation and raw-material orientation, and formation of the national economy complex – the basis for Ukraine accession to the European and global area as a full-fledged subject.

The core of the reconstructive renewal of economy should be the formation of the mature national economic complex on the principles of introversion (aiming at implementing country’s own interests), inclusion (comprehensive involvement in global economic ties, with a view to developing the national economy) and innovative character (implementation of economic transformations on innovation principles). Such an approach, first, necessitates the identification of population’s basic needs and finding the ways of their monetization, transformation into demand, the ways of stimulating supply and the mechanisms of combining it with demand, which envisages the use of both market and reciprocal approaches, changes in the institutes and mechanisms of the monetary policy and management system. Second, it relies on assessing the correlation of global demand for high-tech products and

the availability of the raw material, workforce and technological resources in Ukraine for creating a network of chains for processing raw materials into intermediate and final products. This is the way of creating the nationally rooted technological development that is oriented towards national as well as global markets.

V. Heyets, A. Gritsenko, T. Iefimenko, I. Yegorov, S. Korablin, I. Lulina, V. Sidenko, M. Skrypnychenko, T. Ostashko, I. Prokopa et al.

The Institute of the History of Ukraine issued the three-book edition **“Testing the Fate, Tempering the Will. Ukraine and Ukrainians in XX — Early XXI Centuries”**. The transformation of mental Ukraine into the real one, of people – into a nation, of territory into a state is the through semantic axis of the three books. Geopolitical challenges, inhuman trials, high aspirations and everyday life anxieties of Ukrainians are presented in the chronotope of the “long Ukrainian century” — the epoch of Ukrainian revolution and national liberation war, which has lasted since 1917.

The first book covers the interwar twenty years — the nodal stage of ethnic modernization and mobilization of Ukrainians. The climax of Ukrainian revolution, the battle for Ukraine in the context of World War I and the fate of the largest divided people in Eastern Europe on the background of the victorious march of totalitarian regimes is the leading focus of compre-

hending the historical fate of Ukraine and Ukrainians in this period.

The second book is concerned with Ukrainians in the flames of the Second World War, after the end of which Ukraine became united, and in the Cold War that made possible its sovereignty. The prime focus of researchers is the epoch of global systems opposition, the war as a geopolitical and sociocultural phenomenon that became the system-forming factor of creating modern national conscience.

The third book deals with the epoch of Independence and summarizes the essence of the thirty years of Ukrainian post-totalitarian transit. It analyzes the contradictions of internal development and external challenges, reveals the birth traumas of the totalitarian epoch, idealistic illusions and processes of developing the oligarchic republic, presents events of the three latest Ukrainian revolutions and the russian — Ukrainian war in the global context.

L. Yakubova, V. Danylenko, S. Kulchytskyi, O. Lysenko, V. Holovko et al.

The Institute of the History of Ukraine also published the work **“GAME CHANGER: The War of Russia against Ukraine in the Layers of Time and Spaces of the Past. Dialogues with Historians”**. These two popular-science books in the format of an imaginary dialogue of professional historians with readers present a broad range of issues of Ukraine’s history from medieval times till nowadays. The Ukrainian past is represented here in various contexts of the cardinal change of modern history, which is related to the russian-Ukrainian war of 2014—2022.

They consider in a long historical perspective the russian-Ukrainian confrontation of many centuries, which largely determined the content, configuration and direction of the early modern, new and newest history of Ukraine. Numerous historical stories, problems and facts show the motivation of the current war, the course of its hybrid phase, the nature of putin’s russia and its neo-imperial project aimed at the submission of the post-soviet world.

The socio-cultural and post-totalitarian foundation of ruscism as the determining factor of the full-scale military-political aggression of russia against independent Ukraine was analyzed. It was stressed that this aggression is aimed not merely at the destruction of Ukraine as a state and complete dissolution of Ukrainian identity and replacing it with hybrid projections (like little- or novo-rossiya) but at the destruction of today’s world order.

V. Smolii, H. Boriak, O. Yas et al.

The 6th volume of the **“History of Ukrainian Literature”** (of the 12 planned volumes) was prepared and

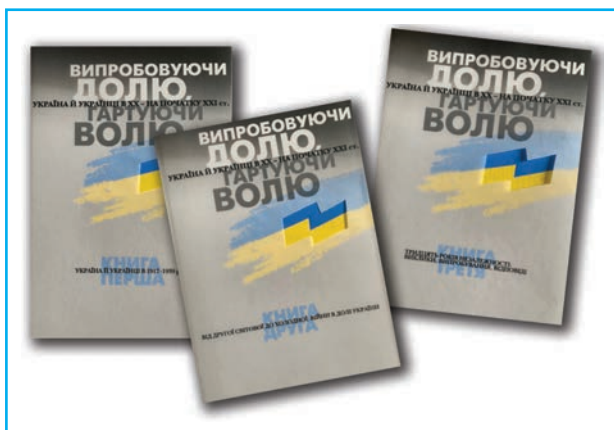

published by T. Shevchenko Institute of Literature of the NAS of Ukraine. It presents the development of *belles-lettres* in Ukraine from 1857 to the end of the 1870-s. Presented in detail was historical and literature situation, peculiarities of this period's literature process, the phenomena that made the contents of "Poetry", "Prose" and "Dramaturgy" sections; the "Chronicle of Events" and "Name Index" are also included. Special attention is given to creative individualities of Marko Vovchok, Leonid Hlibov, Stepan Rudansky, Yurii Fedkovych, Ivan Nechuy-Levytsky, Panas Myrny.

The contents of the volume convincingly show that in spite of all bans and persecution by the tzar regime (Valuyev Circular, 1863; Emsk Act, 1876 etc.), despite the chauvinist attitude of some russian publicists and critics, Ukrainian spirituality confidently declared itself in the world literature.

The appropriate scholarly qualification of the book's authors, its volume corresponding to the topics considered enabled them to show convincingly a radically new interpretation of many literary phenomena (the direct involvement of literature in the national liberation movement, the appearance of new features in the



development of realism, naturalism, in the reverberations of romanticism, early starts of new trends etc.) in more detail than in all histories of the Ukrainian literature published earlier, to consider the literature process, analyze more thoroughly not only the first-rate artistic achievements of the period mentioned but also give attention to little-known and actually unknown facts in the field of Ukrainian poetry, prose and dramaturgy.

M. Bondar, N. Levchyk, N. Boyko, H. Hadzhylova, O. Shubravska, Y. Muravetska, N. Krutikova, L. Ushkalov, I. Betko

Intellectual onboard control system for unmanned aerial vehicle

The analysis of recent armed conflicts and the experience of successful combat operations in Ukraine shows that military units of all levels are employing significant numbers of unmanned aerial vehicles (UAV) of various classes, application levels and combat ranges. Relying on efficient intellectual information technologies for controlling highly dynamic objects, the International Research and Training Center for Information Technologies and Systems of the NAS of Ukraine and the MES of Ukraine developed an intellectual onboard control system for unmanned aerial vehicles that has broad functional capabilities. Such a system enables its users to deal with numerous difficult tasks, in particular, to maintain the specified altitude and speed parameters, neutralize the effects of external disturbances, automatically follow the specified flight trajectory, detect, identify and track potentially dangerous targets.

The proposed system consists of a suit of hardware and software performing operations in automatic and semiautomatic modes for the subsystems like those for automatic UAV flight control, which include UAV's angular position control level, UAV's trajectory control level, altitude and velocity control level; the subsystem of autonomous navigation in the absence of information from satellite systems; subsystems of processing video data for automatic tracking of high-speed objects in real time on backgrounds of various textures, in conditions of a significant change of object's shape (space orientation), at zoom hopping, object defocus



Intellectual onboard control system for unmanned aerial vehicle with a wide range of functional capabilities

and also in conditions of changing image brightness and contrast.

The results obtained by the project authors were implemented in Ukrainian unmanned aerial complex "Spectator-M1", which has entered the service at the Armed Service of Ukraine and the State Border Service of Ukraine.

O.Volkov, M. Komar, Yu. Shepetukha, D. Volosheniuk

Service of global mapping of ionosphere critical frequencies

The European Space Weather Office for Aviation (ESWO) is one of the global space weather centers. It incorporates nine European countries (Finland, Belgium, Austria, Italy, Great Britain, Cyprus, Poland, the Netherlands, Germany) represented by leading national institutions in the sphere of space research. Polish representative in ESWO is the Space Research Centre of the Polish Academy of Sciences (SRC PAN). In the framework of Cooperation Agreement between the NAS Institute of Radio Astronomy and SRC PAN, an innovative service of mapping ionosphere critical frequencies and prompt warning of their decrease (the so-called depressions) was developed and deployed at ESWO.

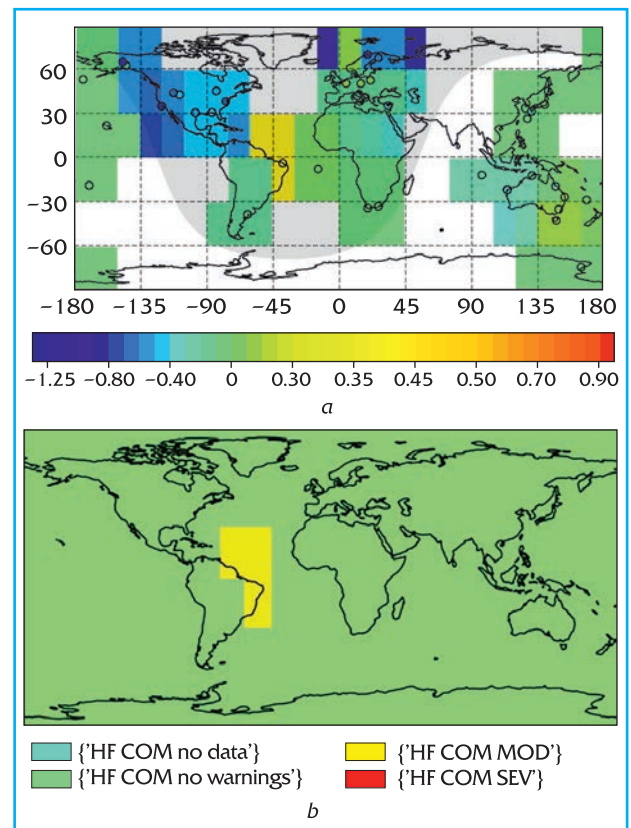

Examples of calculated real-time maps: a – that of global distribution of the depressions of ionosphere critical frequencies foF2 in relation to their median values over the previous 30 days; b – a map of the regions for which a warning about the average (yellow) or high level (red) of foF2 depression may be issued

The service is of vital importance for the fast operation of the ESWO as a global space weather center.

The service forms real-time databases on ionosphere critical frequencies $foF2$, relying on the records of ionosondes that belong to the organizations incorporated into the consortium or to partner organizations. After that, $foF2$ depression is evaluated for each ionosonde in respect of the median value of $foF2$ for the current time over the previous 30 days. Further, data on depressions are processed according to an original algorithm. The results of the processing look like global maps of depressions distribution in polygons of 30° of latitude by 15° of longitude (in accordance with the recommendations of the International Civil Aviation Organization). If the level of depression for some polygon is 30—50%, the recommendation for moderate-level alert (yellow, *HF COM MOD*) is formed, if the depression exceeds 50%, — that for high-level alert (red, *HF COM SEV*). The maps calculated in that way arrive at the ESWO information panel, they are used to form warnings sent on board aircraft.

A. Zalizovski

Georadar for detecting explosive objects

The problem of cleaning up the territory of Ukraine from a large number of explosive objects, military mines in particular, has become especially severe during russian armed aggression. Its urgency will be ever increasing in the post-war period, when thousands of mines will have to be cleared. The ultrawideband impulse ground penetrating radar (IG) is capable of detecting beneath the ground surface the objects that are different in their electrophysical characteristics (conductivity, dielectric and/or magnetic permeability) from the environment. Such objects include, e.g., the so-called plastic mines or mines with minimal metal content. To detect those, short electromagnetic pulses are used. Owing to that, a subsurface object can be localized with the precision of up to several centimeters.

An essential feature of the IG developed is its antenna system, which consists of an emitter and four receiving antennas. Due to such configuration, it became possible to detect the location of a subsurface object in real time, with the radar moving (the depth of object detection is within 20 cm, the width of the examined strip is 40 cm).

The authors implemented the comprehensive approach that provides for the simultaneous minefield work of four robotic platforms equipped with four different sensors: IG, metal detectors, an optic sensor, and a holographic radar. It is important that robot control and the analysis of examination results are carried out remotely via the Internet, which secures sapper's work.

None of the first three sensors can discern with high confidence the mines from safe objects in the ground. So, after detecting potentially dangerous places by each of these sensors (especially, when there are positive reactions of several sensors in the same place), ho-



Georadar for detecting explosive objects: 1 – hardware unit; 2 – antenna system; 3 – robotic platform; 4 – GPS antennas

lographic radar starts its work. It can reconstruct the shape of a subsurface object. That significantly increases the probability of mine detection and reduces the number of false alarms when detected objects are safe.

G. Pochanin, V. Ruban, T. Ogurtsova, O. Orlenko, V. Plakhtii, M. Maiboroda, O. Shuba

Diagnostics of damage to Kyiv TV tower caused by missile strike with the use of uav photogrammetry

Scientists of E.O. Paton Electric Welding Institute of the NAS of Ukraine developed a technology for the technical diagnostics of oversized structures (TV towers, bridges, power lines etc.) using an unmanned aerial vehicle (UAV) for aerial photography and constructing a 3D structure model with photogrammetry method. It is based on geometrical-and-mathematical reconstruction of rays' paths from the object to digital camera sensors at the exposure moment, which permits remote detection of the defective areas, remote determination of exact geometric dimensions of the damaged areas and their location on the structure.

The technology developed can be used for assessing oversized structures that need periodic inspection, since eventually, due to corrosion and excessive loads there could be cracks and erosion of some units and elements. Usually, specialists carry out the inspection at a considerable height, which demands significant additional measures to ensure their safety. However, the use of photogrammetry combined with aerial photography permits a decrease of risks during the inspection of such structures and provides additional reliable information concerning the damage to their elements.

With reliance on this technology, a remote inspection of Kyiv TV tower damage resulting from a missile strike on 1 March 2022 was carried out. An UAV was used to photograph the lower TV storey and its 3D model was built. To compute the positions of structure elements in space, over two thousand photos were taken at different angles and varied distances from the tower. That allowed the assessment of the sizes of defects, determination of their exact localization, visu-

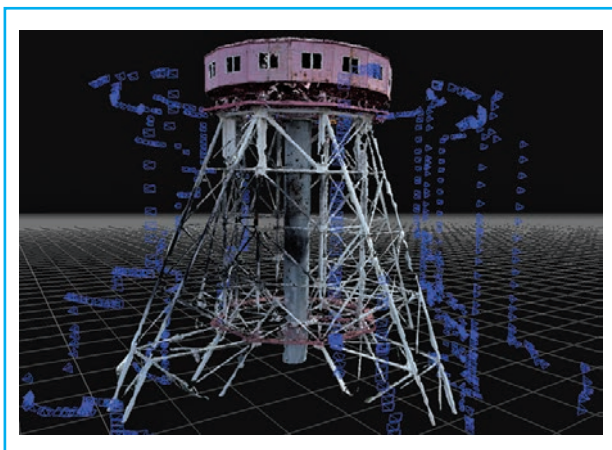

3D model of the damaged TV tower belt

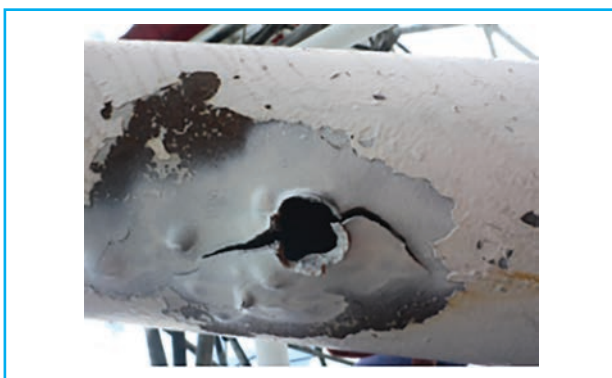

Damaged wall of a TV tower structure element

alization of the damage to the nodes connecting load-bearing elements etc. In particular, over 1000 defects and damaged areas in the TV tower structure were detected and classified. The data obtained made it possible to provide recommendations for a prompt repair and restoration of the TV tower.

L. Lobanov, D. Stelmakh, V. Savitsky, O. Shutkevych

Radial-axial turbines for aircraft gas turbine engines

Scientists of A. Podgorny Institute of Mechanical Engineering Problems of the NAS of Ukraine studied the feasibility of using radial-axial turbines in aircraft gas turbine engines (GTE) intended, in particular, for military equipment. These engines are more compact as compared to the classical axial ones, have a higher energy efficiency (as a rule, in excess of 90%) and a lower cost price. The research was carried out in the framework of the Memorandum on Cooperation and Partnership with Ivchenko "Progress" Zaporizhzhia Machine-Building Design Bureau (ZMDB).

A general methodology of designing radial-axial turbine flow path was developed. It is based on gas-dynamic calculations of different difficulty degrees and on methods of analytical construction of blade rows

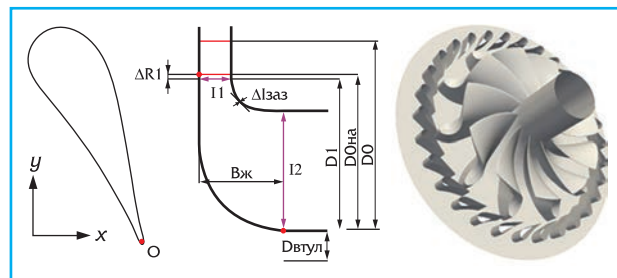

Turbine flow path with profiled rotor blades

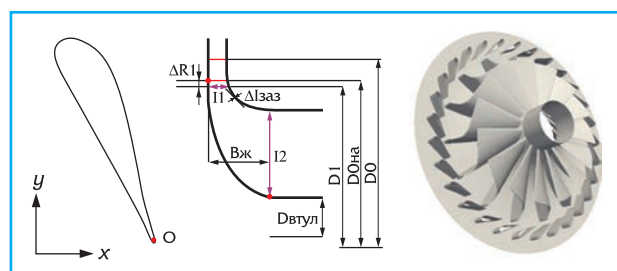

Turbine flow path with "slim" rotor blades

spatial shape. The modeling was based on numerical integration of the Reynolds-averaged unsteady Navier-Stokes equations, using the implicit quasi-monotonic *ENO* scheme of increased accuracy and two-parameter differential *SST* Menter turbulence model. The methodology was realized with the *IPMFlow* software package.

Besides, a design of radial-axial turbine of 150 kW air starter was developed. The spatial shape of its flow path and its characteristics over the entire range of exploitation modes were determined.

Scientists analyzed the turbine version with the application of profiled rotor blades, which are not sensitive to off-design flow angles and provide a high efficiency in a broad range of operation regimes. It proved to be unacceptable due to excessive stress levels and a large mass.

To correct the deficiencies, design methodology was refined and another version of the flow path was developed. The stresses due to centrifugal forces as well as rotor mass were radically reduced to permissible levels. The efficiency of air starter turbine in the nominal mode, despite using "slim" rotor blades, is high — nearly 93%.

In the future, the results obtained are to be used in a broad range of aerial gas turbine engines, which would be beneficial to increasing the efficiency and competitiveness of Ukrainian aircraft industry.

A. Rusanov, R. Rusanov, M. Chugay

Mathematical and computer modeling of rocketry structures deformation

A methodology of studying deformation processes in the structure of complex shapes under intense force load was developed at Pidstryhach Institute for Applied

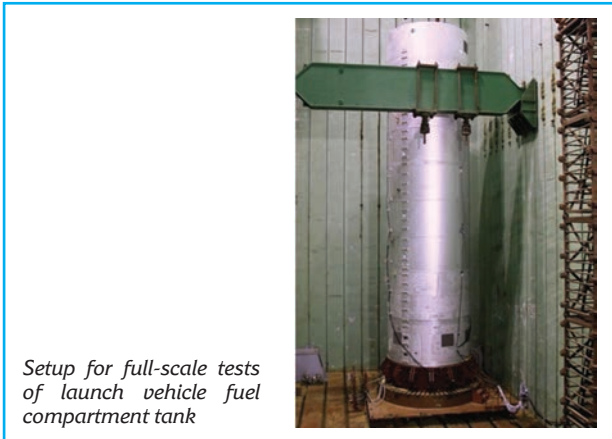

Setup for full-scale tests of launch vehicle fuel compartment tank

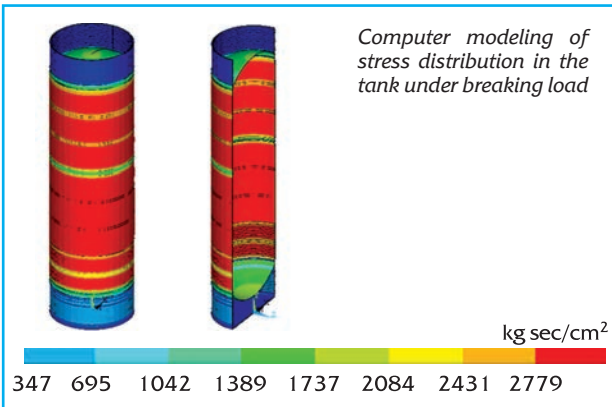

Computer modeling of stress distribution in the tank under breaking load

Problems of Mechanics and Mathematics of the NAS of Ukraine. The methodology makes it possible to obtain an expert evaluation of structure strength by means of mathematical and computer modeling, determine the breaking load of the structure, the place from which fracture will start, and to optimize the structure by selecting proper materials and geometric parameters.

On the other hand, the proposed methodology enables researchers to significantly reduce the number of expensive field experiments when the structure is brought to failure or even abandon them. After determining the breaking load by computer simulation, it is possible to perform a full-scale nondestructive testing on a physical prototype under loads that are significantly lower than the breaking one. If the results of computational and experimental studies coincide, there is no need to increase the load to the breaking point of structure's physical prototype. This will allow valuable materials and funds to be saved.

The comparative analysis of the results of experimental studies (conducted at M.K. Yangel "Pivdenne" Design Office) and computational ones (performed at Pidstryhach Institute for Applied Problems of Mechanics and Mathematics of the NAS of Ukraine) showed their good agreement both in terms of failure location and the value of breaking load.

B. Drobenko, M. Marchuk

Powerful electrical energy storage devices: supercapacitors and their hybrids with Li-ion accumulators

The Institute for Sorption and Problems of Endoecology of the NAS of Ukraine developed new efficient electrode materials for supercondensers (SC). In cooperation with "Unasco-Ukraine" Ltd, SC specimens of 200—3000 F capacitance and 2.7 V operating voltage were produced, as well as modules of 12—90 V operating voltage.

Electrical double layer capacitors, which are more commonly known as ultra- or supercapacitors, are a relatively new type of power storage devices, whose advantages over accumulators are their higher specific power at high efficiency, the possibility of fast charging and long charge-discharge cycling.

The Institute also designed combined power sources with parallel connection of SC and Li-ion accumulator (external hybrid) and was the first to develop hybrid electrochemical systems where both electrodes and the electrolyte have components of SC and Li-ion accumulator (internal hybrid). Prototypes of such accumulators were produced jointly with "Unasco-Ukraine" Ltd.

The systems proposed enable researchers to develop multipurpose power supply systems with excellent characteristics of energy, power and the number of charge-discharge cycles. Of special interest are in-



SC module of 25 kW power and 3.1 kg mass



Hybrid cell of 2.7 V, 3A · hr



Combined module of 16 V, 6A · hr

ternal hybrids, which are similar to accumulators in their performances but are able to provide substantially higher specific power (up to 5 kW/kg) and be fully charged in 5—6 minutes.

Yu. Maletin, N. Stryzhakova, S. Chernukhin, C. Kozachkov

Impulse supersonic ejector for car safety system

The NAS Institute of Hydromechanics developed a promising supersonic ejector for the system of filling car airbags, which in some respects is superior to foreign analogs.

The main advantage of the ejector developed is the possibility of increasing airbag volume and retaining the same filling time, which improves the safety of the driver and passengers of the vehicle without injuring them by the airbag itself. The intake of the ambient air from car's interior, which is provided by the proposed ejector design, reduces the pressure jump in the car cabin and, correspondingly, the probability of getting barotraumas that can lead to tympanic membrane rupture is reduced.

To carry out this research, a multiple approach to studying the properties of supersonic flows was used: theory — computer modeling — experiment. Primarily, the theory of the complex phenomenon of unsteady gas flows in limited volumes, when their speeds are 3—4 times higher than the speed of sound, was studied.

After comparative analysis of the computational results obtained, Institute's researchers proposed and produced an improved version of the ejector, which provides the ejection coefficient nearly 6. This is a fairly high figure. To compare, the known designs of such ejectors have ejection coefficients not more than 3.

Scientists built a flexible multifunctional experimental complex which permits adequate studies of the processes of filling the car airbag with cold air, which imitates the use of pyrotechnics and makes the experiment much safer and less expensive. The experimental results fully confirmed the reliability of the theoretical model of supersonic pulsed ejector.

With certain refinements reducing its cost price, the new system for pulsed filling of the airbags of different

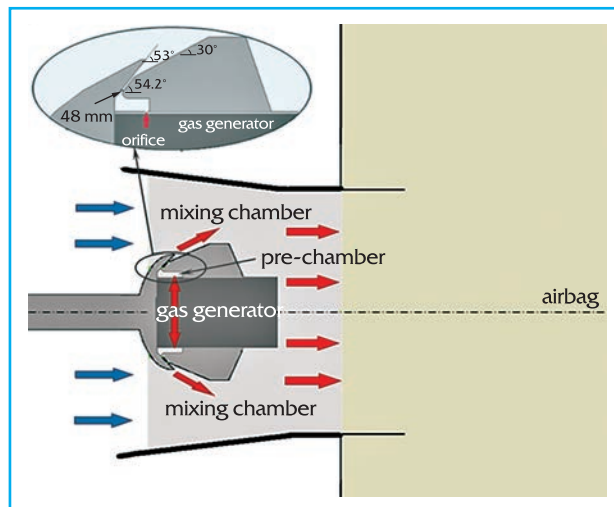

Design of an axisymmetric pulsed supersonic ejector with tangential blowing

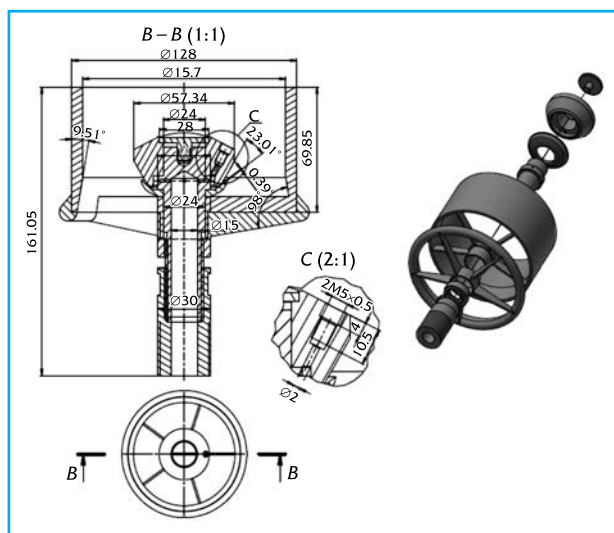

Drawing of the pulsed supersonic ejector developed

volumes can be the basis of the next generation of automobile safety systems.

A team of authors under the leadership of G. Voropaiev

Development of thermostable nanocatalysts for hydrocarbons oxidation in catalytic converters

Scientists of L.V. Pisarzhevsky Institute of Physical Chemistry developed an efficient catalyst for flameless combustion of methane or propane-butane mixture, which is based on nickel and palladium oxides, and cordierite ceramic honeycomb having a low coefficient of linear thermal expansion. They worked out the principal technological parameters of cordierite synthesis with necessary structural and functional characteristics, and the formation of the ceramic honeycomb. Combustion studies of different fuels showed that using the



Flare (top) and flameless (bottom) combustion

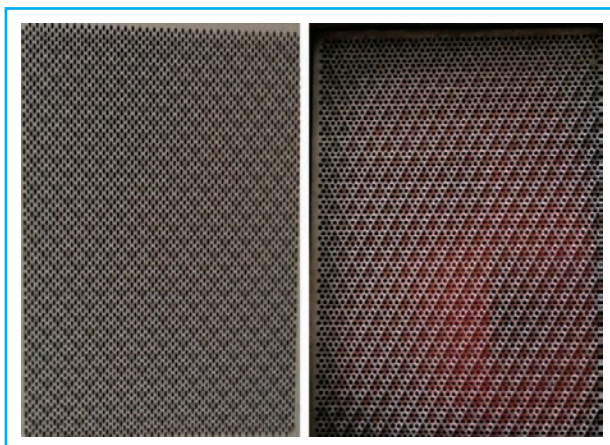

The catalyst before and during work

catalyst developed makes it possible to raise the efficiency of the process, getting it close to 100% (by enhancing fuel combustion), avoid the formation of underburning products: soot and hydrocarbons, and significantly reduce the emissions of CO, NO_x toxic impurities and oxygenated organic compounds.

Resource tests of the catalytic converter for more than 700 hours showed that the catalyst fully retains its activity and stability.

Catalyst production technology was developed and temporary technological regulations for producing a pilot batch of the catalyst were worked out. The use of the developed flameless catalysts will permit an improvement of energy-efficient converters for environmentally friendly fuel combustion when heating business and military facilities both in stationary and field conditions.

P. Strizhak, S. Soloviev, G. Kosmambetova, A. Trypolskyi, A. Kapran

Technology of monitoring the physiological reserve of military personnel and the physiological price of their activities with superminiature electrocardiographs and "cloud" services

The Russian armed aggression necessitated the monitoring of physiological abilities and health status of military personnel both in hostilities and during restoring the combat capability of the units that returned from the frontline.

Scientists of Glushkov Institute of Cybernetics of the NAS of Ukraine developed a technology of monitoring the physiological potential (reserve) of a military and the physiological cost of his/her activities with the help of superminiature electrocardiographs and "cloud" services. The technology is based on two types of superminiature electrocardiographic devices, including those intended for long-term wearing, and advanced software.

The technology relies on the principle of multilateral ECG analysis, which makes it possible to obtain complete and physiologically grounded information that includes 4 aspects: heart rate variability (HRV), ECG amplitude-time indicators, cardiac arrhythmias and the psycho-emotional state, which are based on a specific HRV analysis. Trial operation of the complex both in clinical and non-clinical conditions, including monitoring of military in the hostilities zone, showed the advisability of its use for dealing with a number of tasks:

- providing pre-nosological diagnostics, i.e., obtaining fast assessment of the military's physiological potential (reserve), determining their combat operational readiness and the physiological price of combat or training activities;
- objective assessment of the severity of condition of the patients who need urgent care, as well as the analysis of post-traumatic cardiovascular disorder in patients with combat injuries;
- fast diagnostics of the existing cardiac and vascular diseases of the military, determining the risks of their manifestation and development of complications in the future;
- providing the objective control over the process of physical and psychological rehabilitation of military personnel.

The technology includes, besides the multilateral diagnostics module, the module of fast functional state correction with the help of the so-called metronomized breathing. This component was collaboratively developed by scientists of the NAS Institute of Mathematical Machines and Systems Problems and Glushkov Institute of Cybernetics of the NAS of Ukraine.

The work towards bringing the development to the level of broad practical application is carried out in cooperation with specialists of the Humanitarian Institute of Ivan Cherniakhovskyi National Defense University of Ukraine, with the military of "Chornyi Voron" ("Black Raven") special forces unit of the Armed Forces

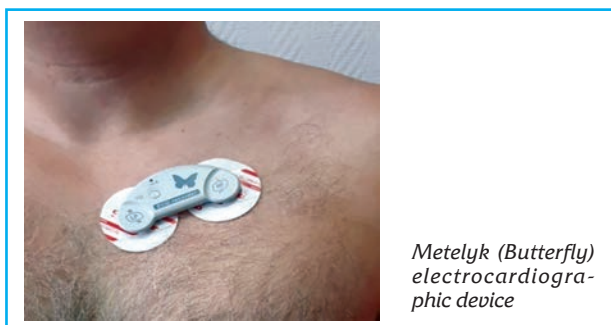

Metelyk (Butterfly) electrocardiographic device

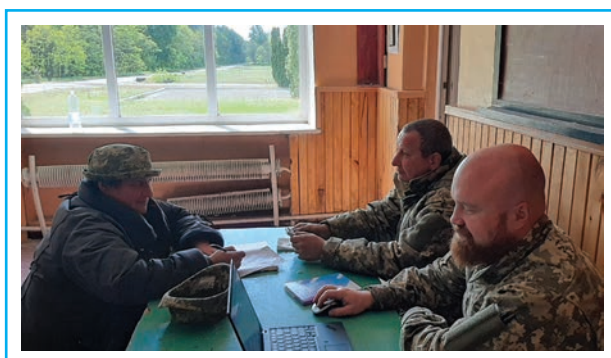

Medical examination of military personnel during measures to restore their combat capability

of Ukraine and with Ukrainian “Solveig” and “Cardiolyse” high-tech companies.

I. Chaikovsky, V. Vishnevsky, T. Ryzhenko, A. Sharypanov

Modified bioactive ceramics for repairing bone defects after gunshot wounds

Scientists of I.M. Frantsevich Institute for Problems of Materials Science developed a novel composite nanostructured material with osteoinductive properties that is based on calcium phosphate ceramics. It is able to induce bone cell development due to its optimized ratio of more soluble spheroid-shaped nanoparticles and less soluble nano-particles of needle-like structure and owing to its system of nano- to macro-sized communicating pores.

Biomaterials for the regeneration of fully functional bone tissue after gunshot injuries were developed with reliance on the results of multi-year research into the advantages of bioactive ceramics based on hydroxyapatite, which is an analog of bone-tissue mineral component but has only osteoconductive properties that support bone formation but do not stimulate it.

The special feature of the modified composite bioactive ceramics developed is the fact that spheroid nanoparticles, dissolving in a physiological medium, significantly increase the concentration of calcium and phosphate ions, which are necessary for bone regeneration, and the pores in the composite increase for further ingrowth into ceramics. Communicating meso- and macropores provide gradual substitution of the material

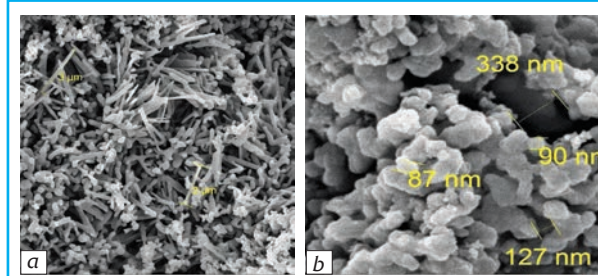

Comparison of the microstructures (at the same magnification) of modified nanostructured bioactive ceramics and imported fast-dissolving bioactive calcium-phosphate ceramics: a) microstructure of modified nanostructured bioactive ceramics showing nano-dimensions of its structural elements; b) microstructure of imported fast-dissolving bioactive calcium-phosphate ceramics showing much larger dense grains

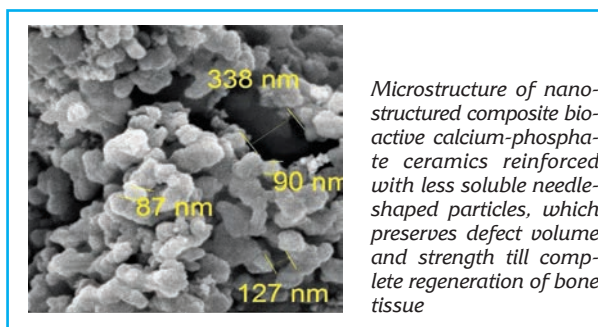

Microstructure of nanostructured composite bioactive calcium-phosphate ceramics reinforced with less soluble needle-shaped particles, which preserves defect volume and strength till complete regeneration of bone tissue

with new bone tissue, while nanopores stimulate the formation of bone cells. Less soluble needle-shaped particles retain the volume of implantation material in the bone defect, which preserves bone volume and strength till complete bone tissue recovery.

Bioactive ceramics is doped with osteotropic elements, silver in particular, to provide it with antibacterial properties, which is important in conditions of growing antibiotic resistance. Pre-clinical *in-vitro* and *in-vivo* trials of the biomaterials developed showed the prospects for their use in the present-day reconstructive surgery for repairing large areas of bone tissue, in view of the fact that, according to statistical data, bone defects due to gunfire limb fractures occur in 76% of the wounded. Of those, 28% are defects of over 6 cm in size, which get infected.

The biomaterials produced are certified in accordance with the State Standards of Ukraine ISO 13485 and technical regulations # 753 for medical products approved on 02 October 2013.

These biomaterials are promising for use in the reconstructive surgery of musculoskeletal system. The development attracted interest of the Ukrainian Military Medical Academy, the State Institution “Institute of Traumatology and Orthopedics of the AMS of Ukraine”, of “DOBROBUT” Clinic, and other Ukrainian hospitals, which are now actively operating on military and civilian patients with gunshot wounds.

S. Firstov, N. Ulianchych, V. Kolomiets

Complex biopreparation for plant protection against pests and diseases

Researchers of D.K. Zabolotny Institute of Microbiology and Virology of the NAS of Ukraine, on the basis of *Pseudomonas chlororaphis* subsp. *Aureofaciens* UKM B-111 and UKM B-300 strains, developed and deployed at Ukrainian enterprises *Haupsin* biopreparation of broad spectrum of activity for crop production industry. It demonstrates not merely antifungal activity characteristic of the numerous plant protection preparations but also antibacterial, entomopathogenic and antiviral properties. It was found that the antifungal and antibacterial activity of *Haupsin* preparation is due to its component strains synthesizing the phenazine-series antibiotics: phenazine-1-carbonic, 2-oxiphenazine-1-carbonic acids and 2-oxiphenazine, which are active against phytopathogenic fungi and bacteria. UKM B-306 strain, like phenazines, also produces antifungal antibiotic pyrrolnitrin. *Haupsin* preparation also exhibited entomocidic properties against a broad range of insect pests due to the presence of an entomopathogenic toxin in its strains. The antiviral activity of *Haupsin* was established on the tobacco mosaic virus model; it is related to the formation of thermostable exopolymers containing neutral monosaccharides. Lipopolysaccharides of B-111 and B-306 strains also proved to be highly active antiviral agents. The structure of their O-specific

Entomocidic activity (CK_{50}^*) of *Pseudomonas chlororaphis* subsp. *aureofaciens* – components of *Haupsin*

Insect species	Development stage	# of strains	
		B-306	B-111
<i>Ptycholoma lecheana</i>	L 2	1.2	8.7
<i>Adoxophyes orana</i>	L 2	0.6	11.7
<i>Pandemis ribeana</i>	L 3	1.1	16.7
<i>Lobesia botrana</i>	L 2	0.9	2.0
<i>Grapholita funebrana</i>	L 5	0.4	1.4
<i>Yponomeuta malinellus</i>	L 3	0.4	1.3
<i>Zophodia grossulariella</i>	L 4	0.6	10.7
<i>Angerona prunaria</i>	L 4	0.3	38.3
<i>Leptinotarsa decemlineata</i>	L 4	4.2	14.7

CK_{50} — is the number of cells (m/ml) that causes 50% insect extermination.



Fitopsin – a variation of *Haupsin* preparation's name depending on its producer

polysaccharides was revealed. They were structurally heterogeneous, represented by linear tri- and tetra-saccharide repeated links, and had unique architecture that had not been described before.

Its broad range of biological activities makes *Haupsin* significantly different from numerous monovalent preparations aimed against a single group of pests or causative agents of diseases.

At present, there are several *Haupsin* producers in Ukraine: "Enzym" State Enterprise, SPC "Cherkasybiozakhyst" Ltd, "Bio Dobryvo" Ltd, "Bitek Activ" private enterprise. Depending on its producer, *Haupsin* biopreparation is sold under different trademarks, in particular, that from "Enzim" SE — as *Haupsin Forte*, while the one from SPC "Cherkasybiozakhyst" Ltd — as *Fitopsin*. *Haupsin* has been introduced in production and economic turnover in accordance with the license agreements concluded with the Institute.

O. Kiprianova, L. Safronova, L. Avdeeva, O. Balko, S. Skrotskyi

SCIENTISTS' AID TO THE ARMED FORCES OF UKRAINE

Since the very beginning of the full-scale Russian aggression, many employees of Academy institutions have been actively involved in volunteer and charitable activities.

The major aid to the armed Forces of Ukraine are developments of NAS scientists.

In the shortest time possible, scientists of Chuiko Institute of Surface Chemistry on their own initiative set up the production of inexpensive high-quality hemostatic drug. They pack it into plastic bottles, add brief usage instructions and transfer it to medical institutions, volunteers and military on the frontline.

Employees of the State Institution "Radma" of L.V. Piszhevsky Institute of Physical Chemistry are sterilizing medical products and sanitary materials around the clock.

Scientists of the NAS Institute of Physics developed 'Hydrobint' preparation, which is based on silver nanoparticles. It disinfects wounds, burns and ulcers and promotes their healing. Now our scientists are producing it themselves and send to field hospitals.

For the needs of oblast bureaus of forensic medicine, the Institute of Cell Biology resumed the production of preparations of immune sera to human blood proteins, which is of great importance in the special conditions of martial law. There are no analogs of such preparations in Ukraine.

Scientists of E.O. Paton Electric Welding Institute produced and sent to the front their own development —



Next-generation heating-and-cooking long-burning stoves sent by scientists of the NAS Institute of General Energy jointly with producer "Promel-Energoavtomatika" Ltd. to Ukraine defenders

a batch of pneumatic medical immobilizing splints. They are used for temporary fixation of traumatized parts of human bodies and transportation of the injured with minimal traumaticity. Besides, the institute sent to military the materials for welding metal structures in the combat zone and transferred PATONMED devices for welding live tissues and necessary surgical instruments to medical institutions.

"Trenar" devices for restoring motor functions of limbs were developed and produced by the International Research and Training Center for Information Technologies and Systems. They were transferred for rehabilitation of wounded soldiers.

Several institutes, in particular, the Institute of General Energy, the Institute of Engineering Thermophysics, E.O. Paton Electric Welding Institute, set up small-scale production of heating-and-cooking stoves. They are used by military in the hottest combat positions in the east and south of our country, and by fighters of Kyiv Territorial Defense.

At the production facility of I.M. Frantsevich Institute for Problems of Materials Science, anti-tank hedgehogs are manufactured. In total, over 600 such structures were made and sent to warfare areas. Besides, the institute designed specialized highly efficient tripods for installing machine guns on cars and organized their production. Over 150 tripods were sent to the Armed Forces of Ukraine.

State Enterprise "Katek" of L.V. Piszhevsky Institute of Physical Chemistry produced armor plates for bulletproof vests and for equipping roadblocks. These products received commendation of military. In addition, the enterprise set up production of solid fuel stoves, which are already used by military and civilians, and of flameless burners as well as gel fuel for military.

Another important direction of the support to the Armed Forces is providing everything they need on a volunteer basis.

Employees of the Institute of Applied Mathematics and Mechanics in the free time from work, as volunteers of the 'Sich' NGO in Cherkasy, weave camouflage nets and costumes for the Armed Forces of Ukraine.

In the very first days of the full-scale Russian invasion, employees of the Institute of Technical Mechanics started making camouflage nets and "kikimora" costumes at "Oberih" and "Descendants of Elsa" volunteer centers, donated two professional sewing machines for making caps, mittens, mattresses.

"Physicists-Lyricists" volunteer group has been functioning at Bogolyubov Institute for Theoretical Physics since 2014. The volunteers developed a unique technology, with which they quickly produce considerable amounts of inexpensive high-quality camouflage nets. In addition to that, they collect and send to the front clothes, food and essentials. They share their experience



Mobilization of the aid to the Armed Forces of Ukraine from Western partners by Academy's cybernetics scientists



Fair "Autumn Vernissage at Botanical Garden" raising funds for the Armed Forces of Ukraine

with colleagues and hold master classes on making camouflage nets. The activities of "Physicists-Lyricists" volunteer groups were repeatedly commended with certificates of honor by military units.

Bulletproof vests, quadcopters and field kits were purchased and donated to Kyiv Territorial Defense units by the International Research and Training Center for Information Technologies and Systems.

The Institute of Renewable Energy provided our military with a portable autonomous solar power plant, an autonomous power system, *Solar Light* lamps for using in warfare areas.

Researchers of George Pukhov Institute for Energy Modelling were involved in organizing field radiocommunication in Kyiv and Kharkiv oblasts, arranging radio intelligence posts, they produced the necessary antennas, purchased equipment for radio intelligence.

Employees of the Ethnology Institute sent medicines and warm clothes to the Armed Forces of Ukraine, and took part in fundraising conducted by Polish patrons to purchase generators for a local community in Rivne Oblast.

Scholars of Ivan Franko Institute provided military on the frontline with first aid kits and tourniquets, medicines, radio transmitters and thermal imagers.

T. Shevchenko Institute of Literature hosts volunteer organization 'Hrushevsky Barricade: the Spirit of Great Warriors', which is headed by Mykola Zhulynsky. Since the beginning of Russia's military aggression they have conducted dozens of humanitarian trips and delivered tactical equipment, medicines, hygiene products, foodstuffs, generators to units of the Armed Forces, Territorial Defense, and local communities of Chernihiv, Kyiv, Sumy, Kharkiv, Mykolaiv and Zaporizhzhia oblasts.

The team of Vasyl Stefanyk Lviv National Scientific Library of Ukraine since 2014 has been involved in the activities of NGO "Lviv Volunteer Kitchen", which produces dry food for Ukrainian military. Every month, the volunteer kitchen sends 17.000 dry rations to the front.

Financial aid was provided for the Armed Forces of Ukraine as well. Members of the NAS of Ukraine transferred a part of their academic payments. Several laureates of the 2021 nominal prizes of the NAS of Ukraine donated the received funds as an aid to the Armed Forces. Members of NAS Presidium, employees of its apparatus and of many Academy institutions transferred parts of their salaries to the Ukrainian army.

At M.M. Gryshko National Botanical Garden, there was an action of planting the Alley of Ukraine Defenders — 120 decorative apple trees grown near Bakhmut town in Donbas in the garden nursery that was ruined by Russian occupants. The botanical garden also organized several plant fairs to raise funds for Ukrainian military.

A charitable fundraising event "Plucked Flowers", including a concert and an exhibition, was held at the Institute of Ethnology. During it, funds for the Ukrainian Armed Forces were collected.

INTERNATIONAL COOPERATION. AID FROM FOREIGN PARTNERS



STAND WITH UKRAINE — this slogan can be seen in the cities and towns of the European Union, on the government portal of the European Commission, on the website of the European Organization for Nuclear Research etc.

Since the very beginning of the unmotivated war unleashed by Russia against sovereign Ukraine on 24 February 2022, the National Academy of Sciences of Ukraine repeatedly addressed the world scientific community with appeals to join forces and do everything possible to protect Ukraine and the entire democratic world against Russian military aggression. Fellow scientists were given the true picture of the consequences of this aggression — bombing peaceful people, destruction of civilian, scientific in particular, infrastructure. The NAS Commission for Ukraine integration into the European research area sent to international and foreign partners calls for the urgently needed support to Ukrainian science, in particular, by providing research grants to NAS institutions and scientists who had not left Ukraine, for restoring the damaged scientific facilities and research equipment. The appeals also contained proposals to start programs in support of Ukrainian scientists and allocate funds for such support in the existing international scientific programs.

The Russian aggression was adequately assessed by the global scientific community. The NAS of Ukraine received over fifty letters from international and foreign organizations, which not merely expressed their support but openly condemned aggressor's actions. National academies of sciences of the G7 countries made

a joint statement in the first days of aggression. Letters of support also came to the NAS of Ukraine from the academies of sciences, leading scientific organizations, research teams and individual scientists of Austria, Azerbaijan, Croatia, the Czech Republic, Denmark, Estonia, France, Germany, Greece, Japan, Latvia, Lithuania, Moldova, Montenegro, Poland, Romania, Slovakia, Spain, the USA, as well as international organizations — the European Federation of the Academies of Sciences and Humanities, the European Physical Society, European Society for the Study of English, the Association of European Operational Research Societies, Applied Superconductivity Educational Foundation, the International Science and Technology Union of Guangdong Province (China) and others. Representatives of 10 EU countries at Brussels research and innovation offices operating under the European Commission made a joint statement on the strong condemnation of Russian aggression and called for preventing the destruction of Ukrainian research infrastructure, which is an integral part of the European research area.

Numerous international and foreign scientific organizations stopped their cooperation with Russian and Belarusian research organizations. In particular, the European Organization for Nuclear Research as early as on 8 March 2022 suspended the Russian Federation's observer status and on 17 June adopted the decision to terminate cooperation with Russian and Belarusian scientists after their contract completion in 2024.

The NAS of Ukraine, on its part, cancelled agreements on scientific cooperation with the Russian Academy of Sciences, its Siberian branch, M.V. Lomonosov Moscow State University, Moscow Institute for Physics and Technology, Joint Institute for Nuclear Research (city of Dubna), as well as the NAS of the Republic of Belarus. The National Academy of Sciences of Ukraine withdrew from the International Association of the Academies of Sciences.

NAS scientists who at different times were elected foreign members of the Russian Academy of Sciences submitted a group statement of withdrawing from its membership. The NAS of Ukraine also approved a resolution on terminating any forms of scientific cooperation with Russian organizations and scientists, and deprived of its distinctions and awards those public figures of the aggressor country, representatives of science and culture who had supported aggression against Ukraine.

On 3 March 2022, the International Union of Academies of Sciences called its members to support externally displaced Ukrainian scientists. Early in June, at the forum 'Academic cooperation in support of Ukrainian scientists', US national academies of sciences, engineering and medicine, the academies of sciences of Poland, Denmark, *Leopoldina* Academy of Sciences (Germany),

European Federation of the Academies of Sciences and Humanities, London Royal Society agreed with the NAS of Ukraine the practical steps in support of science in Ukraine. They provided for funding of the Ukrainian scientists who are temporarily staying abroad with internship and traineeship scholarships, grants for collaborative scientific studies. Also envisaged was providing Ukrainian scientists with free access to *Scopus* and *Clarivate* databases, to the full texts of articles, books and journals published by *Springer Nature*, *John Wiley&Sons*, *Taylor&Francis*, *Emerald*, *Oxford University Press*, *Cambridge University Press*; exemption of Ukraine's scientific institutions from paying membership fees to international scientific organizations, and scientists — from fees for participation in conferences etc. The Austrian Academy of Sciences offered support to Ukrainian scholars under its mobility program "Joint achievements in science and humanities" in the form of conducting research in Austrian research institutions.

The European Commission created portal "European research area for Ukraine" (*ERA4Ukraine*) — a joint center for providing information and support services for Ukrainian scientists who were forced to go abroad. Besides, EC announced a scholarship program that would enable researchers from Ukraine to continue their work at academy and non-academy institutions of EU member states and the countries that are associate members of the EU "Horizon Europe" programme, yet keeping in touch with Ukraine's scientific community.

On 26 June, the European Commission reviewed the working program 2021—2022 under Euratom Research and Training Programme. As a response to the war in Ukraine, the decision on financial support to Ukrainian participants in controlled thermonuclear fusion research was added. On July 4—5, the General Assembly of *EUROfusion* and the ceremonial opening of a new research project under "Horizon Europe" programme took place and were attended by EC representatives and the leaders of European scientific community. The decision on allocating an additional € 2.5 million budget to the Ukrainian beneficiary was officially announced there. These funds are to be directed to restoring the scientific infrastructure, research equipment in particular. Ukraine was also exempted from paying fees to Euratom in the coming years.

German scientific society Max Planck Institute started two programs of supporting Ukrainian scientists who head research groups in Ukraine and Ukrainian scientists who temporarily left their country because of the war. German Research Foundation (*DFG*) expanded its criteria of funding via Walter Benjamin Programme to finance research that could involve scientists from Ukraine. Leibnitz Association of German research institutes also joined the support of Ukrainian researchers. The scholarship program *Researchers at Risk Fellow-*



Participants of the forum "Academy cooperation in support of Ukrainian scientists", Warsaw, Poland



International and foreign scientific organizations terminate cooperation with Russia.

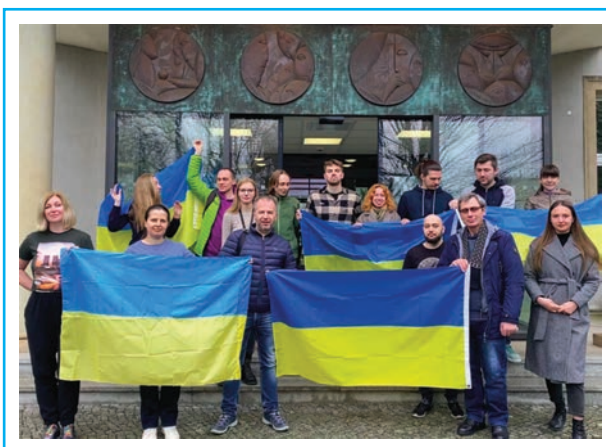

European Commission enhances support to Ukraine

ship, which was started in Great Britain in March, provided for the support of over 130 Ukrainian scientists. The Ministry for higher education, research and innovation of France allocated additional funds for its scientific centers that were ready to receive Ukrainian researchers. Swiss government offered federal scholarships for Ukrainians via its Federal Commission for providing scholarships for foreign citizens. The Swedish Foundation for Strategic Research announced its readiness to support Ukrainian scientists who stayed on the territory

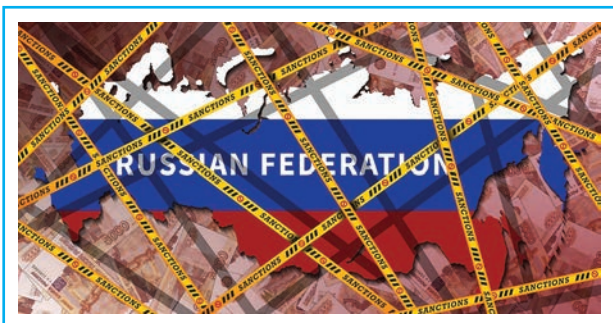

Support of Ukraine by international scientific community



Ukrainian research physicists at the Institute of Solid State and Materials Physics of the Leibnitz Association of German Research Institutes, Dresden, Germany

of the country and allocated SEK 34 million for individual grants. Austrian Vienna Center for Disarmament and Non-Proliferation started a new research program *Emergency Fellowship Program — Ukraine* for Ukrainian scientists and experts in non-proliferation, disarmament and arms control. Czech universities offered various forms of support to Ukrainian scholars and students. Estonian Research Council publicized its program in support of Ukrainian researchers who had arrived in Estonia. The Finnish Society of Sciences and Letters started a competition for grants to Ukrainian scientists who stayed in Finland. Special scholarships for Ukrainians were envisaged by scientific research institute *Academia Sinica* (Taiwan).

All in all, Ukrainian scholars whom the war made leave Ukraine received over 300 grants for traineeships and continuation of their research at the institutes and universities of more than 30 countries. In particular, Germany funded over 80 grants to Ukrainian scientists,

Poland — over 55, Italy, the USA, France, Sweden, the Czech Republic — nearly 20 each, Switzerland — more than 10.

Grant support to the scientists who continued to conduct research in Ukraine is also important. On May 31, 2022, the European Federation of Academies of Sciences and Humanities and *Breakthrough Prize Foundation* launched a program in support of scientists and research institutions which suffered from the war in Ukraine. The program was worth \$ 1.5 m and had two lines of funding: the first ensured one-year financing for the European academic host institutions that were able to receive displaced Ukrainian scientists and the other — funding for scientific institutions in Ukraine that were damaged by hostilities: for restoring research facilities and continuing their work. Four such grants were provided to NAS institutions.

Wolfgang Pauli Institute (Vienna, Austria), very soon after the beginning of the war, gave support to its Ukrainian colleagues — scientists in mathematics, physics and related natural sciences who remained to work in Ukraine, paying them scholarships. The Institute provided scholarships to all 26 applicants — 19 of those were NAS research associates. Later, the support program was continued.

Three grant programs were started by the Ukrainian Science and Technology Center. In particular, on behalf of *IEEE Magnetism Society*, under the program "Magnetism for Ukraine — 2022", collective and individual grants were provided to 22 applicants who worked in the field of magnetism, spintronics or related science areas; 15 grants were received by NAS researchers. According to program rules, its performers are to work in Ukraine for at least 50% of the grant term.

The request from NAS President Anatoly Zagorodny for considering the possibility of granting humanitarian aid to the NAS of Ukraine in the form of advanced scientific instruments was sent to 15 leading research equipment manufacturers in June. As soon as in late August, four companies, namely, *Agilent*, *Bruker*, *Carl Zeiss* and *Analytic Jena* decided to donate the very necessary devices to the Academy. According to the preliminary agreement, their total number would be about 20, among them being confocal, light and electron microscopes, UF-VIS-IR spectrometers and spectrophotometers, gas and liquid chromatographers, diffractometers etc.

SCIENCE POPULARIZATION, PUBLIC RELATIONS

The presence of the National Science of Ukraine in the information area is becoming stronger and more extensive, its communicative activity is increasing, and the efficient interaction of scientists with media and public is being established. In particular, measures are taken to inform general public on the important role of science in today's world, the life of the Ukrainian state, as well as present important results of NAS institutions' work and the problems of national science sphere. Academy scientists are proactively collaborating with media — they take part in TV and radio programs, publish articles on the pages of printed and Internet editions, write posts on scientific subjects in social networks and participate in popular-science projects. Special attention is given to filling the official NAS web site and its Facebook page with the information which is of public interest. All that promotes the publicity and openness of Academy's activities to society.

In 2022, the full-scale Russian invasion interfered with full-blown extensive events aimed at popularizing science: the All-Ukraine Science Festival, which is traditionally held in May, "Science Days" — the project launched by young NAS scientists for familiarizing the public with the work of researchers, the achievements of world and Ukrainian science.

Hostilities made the organizers of numerous popular-science activities change their formats and use mixed (online/offline) or fully online mode.

Academy scientists became actively involved in planning and holding several popular-science and interactive events in the framework of the International Day of Fighting Cancer, observing the International Day of Plant Health in Ukraine, the World Embroidery Day, the Day of Field 2022 etc.

Last year, «Opening "Science for All"» action, initiated and implemented by the NAS *Akademperiodyka* Publishing House with the support of Science Publishing Council of the NAS of Ukraine, was continued. Every week, *Akademperiodyka* opened free access to yet another book of the Academy's book series "Science for All", placing on its web resource the full text of the book.

The provision of various lecture courses by NAS scientists went on. Among those was a cycle of online

lectures within 'Real science' and 'Scientific meetings' projects, as well as a cycle of archeology lectures 'What archeology tells us about'.

All the year round, the NAS National Museum of Natural History traditionally invited its visitors to various interesting events — excursions, exhibitions, demonstrations, quests, lectures and interactive programs. Every month, the Museum offered a new program covering varied subjects and interesting facts from the world of science and nature for visitors of different ages: preschoolers, schoolchildren and adults.

To stimulate young people's interest in science, Glushkov Institute of Cybernetics jointly with Uzhhorod National University started a new contest *Glushkov-CYBER* — a competition via research. Another competition cycle for popularizing scientific knowledge was organized by IT specialists in cooperation with Kyiv Academic University. On the initiative of Kyiv Academic University, a video marathon "Ukrainian scientists against war" was organized. It presented scientists' views of the ongoing events and their appeals to the world scientific community to stand with Ukraine.

Scientists of the research department of functional materials chemistry at S&T Complex "Institute for Single Crystals" of the NAS of Ukraine launched *Kharkiv Chemical Seminar* and made it available for a wide circle of scientists. Leading chemistry scientists of the world delivered presentations and lectures there. Over 10 months of *Kharkiv Chemical Seminar's* work, 20 lectures were provided, which were attended (either directly or through the YouTube channel) by more than 4000 participants.

The popular-science events organized by research associates of the Main Astronomical Observatory of the NAS of Ukraine have already become traditional, among them being the *Day of Telescope — 2022* and *Astroautumn in Holiiv*. On the permanent basis, YouTube channel *Everything about Universe* broadcast popular-science program "Talking about Universe with Ivan Kriachko" authored by a scientist and well-known Ukrainian popularizer of astronomy. Ivan Kriachko heads the laboratory for methodological and information support of education and science (astronomical) at the Main Astronomical Observatory of the NAS of Ukraine and Taras Shevchenko National University of Kyiv.

The program "On science. Competently" was regularly aired on the NAS YouTube channel and won ever-increasing popularity. In the framework of the project, leading Academy scientists were speaking in their interviews to NAS academician Volodymyr Semynozhenko about the most relevant and significant research results and S&T developments that are of major importance for the life of every person and the whole state. This project was a useful platform for scientific



The Telescope Day – 2022 in the Main Astronomical Observatory of the NAS of Ukraine (24 September 2022)



Science and Innovation Museum, opened by the National Center "Junior Academy of Sciences" in Lviv

communication of researchers both among themselves and with society. Over the time of its implementation, renowned scholars in biology, genetics, medicine, chemistry, physics, astronomy, mathematics, optoelectronics, aircraft building, political science, economics, demography, sociology etc. were invited to talk.

In 2022, NAS scientists closely cooperated with Ukrainian media, in particular, TV channels: Rada, Priamyi, Inter, 5th kanal, TRK Kyiv, Ukraina24, Espresso TV, Apost-

rof TV, Internet channels: Hromadske telebachennia, I-UA.TV, radio stations UA: Ukrainske radio (UR-1, Promin, Kultura), Hromadske radio, Radio Svoboda, Radio NV. Collaboration continued with printed periodicals: "Den", "Holos Ukrainy", "Uriadovyy Kurier", "Svit", "Ukrainskyy Tyzhden", "Vechirniy Kyiv", "Fakty", popular-science magazine "Kunscht", Internet editions: "Dzerkalo Tyzhnia", "Ukrainska Pravda", "BBC NEWS Ukraina", "Tsenzor. NET", "ZAXID.net", "Glavcom", "Gazeta.ua", "Apostrof", "Livyy Bereh", "Wonderzine", "LIGA.Life", "Telegraf", information agencies: "Ukrinform", "Unian", "RBK-Ukraina" et al.

Collaborating with various media, NAS scientists carried out constant educational work in society, were engaged in debunking myths generated by aggressor's propaganda — they analyzed the historical roots of rushism, its philosophy and ideology, predicted economic, social, demographic, environmental consequences of the aggression, war challenges for the religious life in Ukraine, answered the most frequently asked questions about nuclear weapons, the losses caused by the war, possible ways of compensation for them etc.

Collaboration with foreign media became extremely active. Highly reputed American and European editions published interviews given by NAS President academician Anatoly Zagorodny, articles and comments by leading Ukrainian scientists. Foreign journalists focused on the state of the scientific sphere during the war, losses and destruction, search for opportunities for the recovery and development of Ukrainian science.

In 2022, the NAS Commission for communications with society and the popularization of scientific activities continued its work. It approved the procedures of nominating the candidates and processing the documents for entering the competition for NAS Prize "For Popularizing Science". At the year end, the contest itself was announced. The prize will be annually awarded to the media and their representatives, researchers and the organizers of independent projects for the best material about the accomplishments of scientists, the activities of scientific institutions and the Academy as a whole, as well as for promoting science popularization and enhancing the prestige of scientist profession in Ukraine. The winners of the prize will receive a diploma and a monetary reward at the annual session of NAS General Meeting.

DISTINCTIONS AND AWARDS OF NAS SCIENTISTS

Awarded with V.I. Vernadsky Gold Medal of the NAS of Ukraine were NAS academician V.D. Pokhodenko for his outstanding achievements in the physical chemistry of free radicals, conductive polymers and nano-systems, and professor M. Larsson (Sweden), a foreign NAS member — for prominent achievements in chemical physics and molecular spectroscopy.

B.E. Paton Gold Medal of the NAS of Ukraine was awarded to NAS academician L.M. Lobanov, deputy director of E.O. Paton Electric Welding Institute — for developing technologies of deformation-free welding of products of rocket and space industry, developing and implementing laser interferometry methods for assessing the quality of welded joints, and to NAS corresponding member O.P. Korostelev, Director-General of the “Luch” State Kyiv Design Office, for developing novel weaponry and military equipment and organizing their series manufacture.

Significant gains in promoting international scientific cooperation were marked by bestowing the titles of *Doctor Honoris Causa* of the NAS of Ukraine on the President of the National Academy of Sciences of the USA M.K. McNutt and the President of the Polish Academy of Sciences J. Duszyński.

In 2022, seven employees of NAS institutions, organizations and enterprises were honored with state awards of Ukraine. Awarded for their personal contribution to state development, socio-economic, S&T, cultural and educational progress of the Ukrainian state, strengthening the authority of Ukraine, significant labor achievements, multi-year conscientious work were:

NAS academician [I.M. Dziuba], adviser of NAS Presidium — with Order of Prince Yaroslav the Wise V Class;

NAS corresponding member V.P. Gusynin, department head at Bogoliubov Institute for Theoretical Physics — with Order of Merit, III Class.

For considerable accomplishments in strengthening Ukrainian statehood, courage and dedication exhibited in defending the sovereignty and territorial integrity of Ukraine, substantial personal contribution to the development of various spheres of social life, defending our state’s national interests and for significant achievements in science, awarded with the medal “For Labor and Victory” were:

A.O. Zaporozhets, senior research associate of the NAS Institute of General Energy;



2021 laureates of Borys Paton National Prize of Ukraine with the President of the NAS of Ukraine academician Anatoly Zagorodny and the President of the NAMS academician Vitaliy Tsybaliuk



Presentation of the prizes named after outstanding scientists of the National Academy of Sciences of Ukraine by NAS President academician Anatoly Zagorodny



Young scientists of the Academy received state awards of Ukraine

V.K. Malolitneva, academic secretary of V.K. Mamutov Institute of Economic and Legal Research;

A.M. Riabokon, research associate of the NAS Institute of Food Biotechnology and Genomics;

K.V. Savchenko, academic secretary of G.S. Pisarenko Institute for Problems of Strength.

The honorary title "Merited Culture Worker of Ukraine" went to V.I. Dmytruk, senior research associate of the NAS Institute of the History of Ukraine.

For developing information and analytical platform for counteracting aggression, the National Security and Defense Council of Ukraine awarded its Honors III Class to scientists of the National Center "Junior Academy of Sciences": deputy director for scientific work, senior research associate O. Ye. Stryzhak and V.V. Prykhodniuk, the head of the department for developing and using intelligent network instruments, as well as M.V. Nadutenko, the head of the informatics department of the NAS Ukrainian Lingua-Information Fund.

Borys Paton National Prize of Ukraine was awarded to D.M. Volochniuk, department head at the NAS Institute of Organic Chemistry, and S.V. Kolotilovacting, acting deputy director of L.V. Pisarzhevsky Institute of Physical Chemistry for their work "Development of or-

ganic compounds for present-day medicine — an important element of Ukraine security and defense capability".

35 researchers of the Academy became laureates of President of Ukraine Prize for young scientists, the Verkhovna Rada Prize for young scientists was awarded to 11 scientists. Three employees of the Academy were marked with Verkhovna Rada Diploma and Verkhovna Rada Honorary Diploma, four NAS employees received valuable presents from the Head of Verkhovna Rada of Ukraine.

61 Academy employees became the laureates of prizes named after prominent scientists of Ukraine.

To honor personal courage and patriotism in defending the sovereignty, independence and territorial integrity of Ukraine during the full-scale armed aggression of the Russian Federation, personal contribution to scientific, administrative, economic and technical support to ensuring Academy institutions' functioning, charitable and volunteer activities, National Academy of Sciences of Ukraine presented 605 people with signs of honor, in particular:

for a significant contribution to the defense of Ukraine territorial integrity, direct participation in rebuffing the armed aggression of the Russian Federation, personal courage and patriotism — 347;

for a significant personal contribution to scientific, administrative, economic and technical support to the activities of scientific institutions, organizations and enterprises of the NAS of Ukraine during the full-scale armed aggression of the Russian Federation against Ukraine — 173;

for a substantial personal contribution to supporting the Armed Forces of Ukraine, other military formations and the civilians affected by the full-scale armed aggression of the Russian Federation against Ukraine, active charitable and volunteer activities — 85.

The title of life honorary member of the British Cave Research Association (BCRA) was awarded to NAS corresponding member O.B. Klymchuk, research associate of the NAS Institute of Geological Sciences. He was also elected an honorary member of Hungarian Speleological Society (HSS).

For the accurate forecast of GDP and consumer inflation in Ukraine in 2020—2021 (2021 *Forecast Accuracy Awards Ukraine*), the leading international organization for economic studies *Consensus Economics* marked with *Eastern Europe 2021 Forecast Accuracy Award* the scientific team of the NAS Institute for Economics and Forecasting, led by institute's director NAS academician V.M. Heyets, and chief researcher of the department of economic development modeling and forecasting NAS corresponding member M.I. Scrypnichenko.

Ukrainian scientist Marina Viazovska was declared one of the four winners of the most prestigious mathe-

mathematical award — Fields Medal (in the world of mathematics it is considered to be the equivalent of the Nobel Prize) at the ceremony of the International Mathematical Union in Helsinki (Finland). She heads the Chair of Number Theory at the Federal Polytechnic School of Lausanne (Switzerland) and got her Candidate-of-Science degree at the NAS Institute of Mathematics.

L'Oréal foundation and UNESCO honored mathematician Olena Vaneeva, who was one of the 15 laureates of the international prize "For Women in Science" and represented Ukraine on the world arena at UNESCO Headquarters in Paris (France), for outstanding scientific achievements in mathematics.

The prizes of Kyiv Mayor for significant achievements in the development of Ukraine's capital — the hero city Kyiv 2022 — for scientific achievements, in particular, went to five young NAS scientists, while 10 young Academy scientists became the winners of the annual all-

Ukraine contest "Young Scientist of the Year" for 2022 in several nominations.

167 scientists were marked with honorary awards: "For scientific achievements" — 27, "For training young scientists" — 38, "For professional achievements" — 77, "For promoting science advancement" — 14, the award for young scientists "Talent, inspiration, labor" — 9, the memorial award in honor of the NAS centenary — 2.

214 people and the teams of *Naukova Dumka* Scientific and Publishing Enterprise of the NAS of Ukraine and H.S. Skovoroda Kharkiv Pedagogical University were honored with NAS commendations.

140 people and the teams of the International Research and Training Center for Information Research and Systems of the NAS of Ukraine and the MES of Ukraine, and the NAS Institute for Problems of Cryobiology and Cryomedicine were awarded with the Honorary Diploma of NAS Presidium and the trade union of NAS workers.

BACKGROUND INFORMATION. STATISTICAL DATA

Structure of the NAS of Ukraine

The structure of the NAS of Ukraine includes 3 sections and 14 departments, which incorporate 146 research institutions. Research-and-production organizations (design offices, pilot production facilities etc.) operate within some scientific institutions. Functioning within some research institutions are science objects that have the status of National Asset (nuclear, physical and astronomical research facilities, testing equipment complexes, archive scientific collections and museum displays, plant genetic funds, collections of microorganism strains and plant lines, cell banks, landmarks of history and culture etc.), as well as centers for shared use of scientific equipment.

Research organizations that have the National Institution status:

- V.I. Vernadsky National Library of Ukraine
- National Science Center "Kharkiv Institute of Physics and Technology"
- "Olbia" National Historical and Archeological Reserve
- M.M. Gryshko National Botanical Garden
- "Sofiivka" National Dendrological Park
- National Museum of Natural History
- V. Stefanyk National Scientific Library of Lviv
- National Center "Junior Academy of Sciences" of the MES of Ukraine and the NAS of Ukraine.

Functioning in the Academy are **five Regional Science Centers** of dual subordination to the Ministry of Education and Science of Ukraine:

- Donetsk Science Center (Kramatorsk, Donetsk Oblast)
- Western Science Center (Lviv)
- Southern Science Center (Odesa)
- North-East Science Center (Kharkiv)
- Prydniprovskiy Science Center (Dnipro), as well as the Center for Evaluating Research Institutions and Scientific Support to Regional Development (Kyiv).

The statutory activities of Crimean Science Center and its funding from the NAS budget were suspended in 2014.

DISTRIBUTION OF INSTITUTIONS ACROSS SECTIONS AND DEPARTMENTS

Department	The number of scientific institutions	The number of R&D organizations	Objects with the National Asset status	Centers for shared use of equipment
Section of Physical, Engineering and Mathematical Sciences				
Mathematics	3	—	—	—
Informatics	8	—	—	—
Mechanics	7	3	3	7
Physics and Astronomy	15	2	9	16
Earth Sciences	13	1	—	5
Physical & Engineering Problems of Materials Sciences	12	19	1	12
Physical & Technological Problems of Energy Engineering	10	1	2	4
General Biology	5	2	2	6
Section of Chemical and Biological Sciences				
Chemistry	13	6	—	11
Biochemistry, Physiology & Molecular Biology	8	2	5	9
General Biology	21	1	19	12
Section of Social Sciences and Humanities				
Economics	9	—	—	—
History, Philosophy & Law	15	3	5	—
Literature, Language & Art Studies	7	—	4	—

Regional structure of the NAS of Ukraine

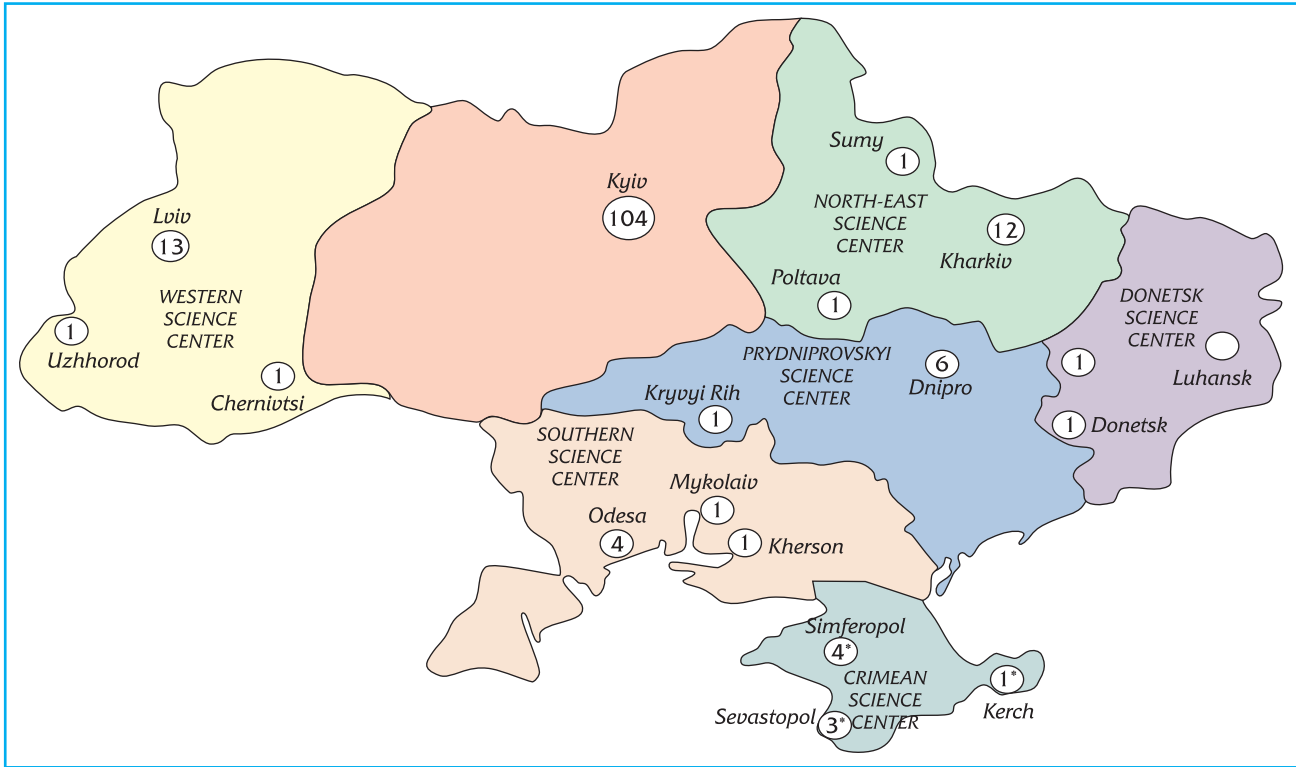

Figures in the map show the number of research institutions

* The status of NAS institutions located in the Autonomous Republic of Crimea is defined by the Law of Ukraine "On guaranteeing the rights and freedoms of citizens and legal regime on the temporarily occupied territories of Ukraine"

Conducting scientific research

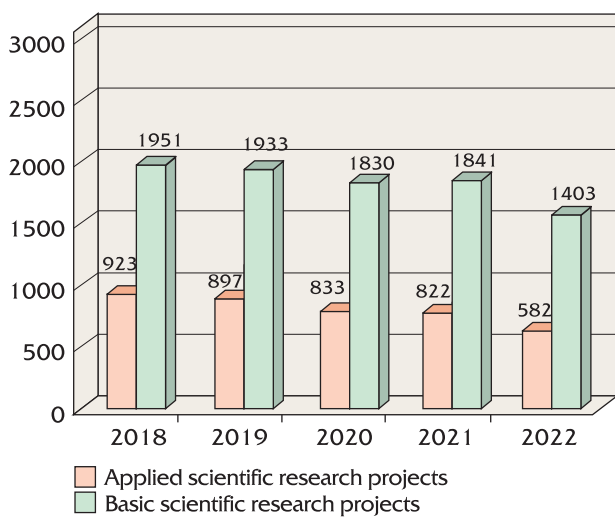

The number of implemented research projects financed from the general fund of the State Budget

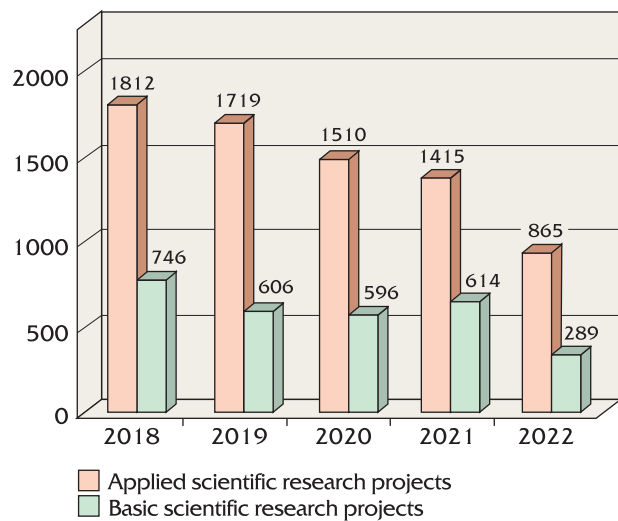

The number of implemented research projects financed from the special fund of the State Budget

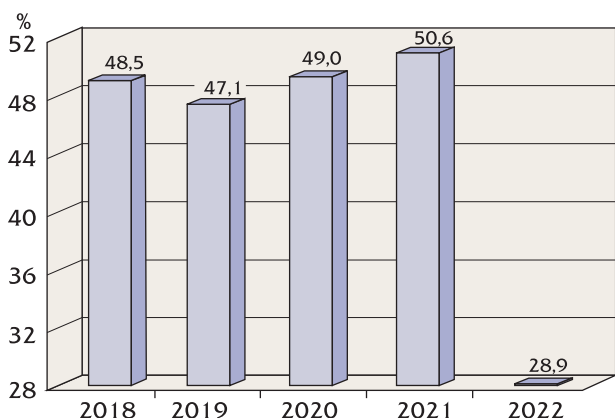

The part of targeted-program and contest projects of NAS institutions in the total number of scientific research works

Targeted-program and contest-based research projects of the NAS of Ukraine in 2022 involved the research conducted under:

- 5 NAS targeted programs of basic research;
- 5 NAS targeted programs of applied research;
- and were based on the results of:**
- contest of S&T (innovation) projects;
- contest of scientific and S&T projects implemented in the direction "Support to scientific and S&T (experimental) developments that are of top priority for the state";
- contests of research projects of young scientists of the NAS of Ukraine.

Publication activity

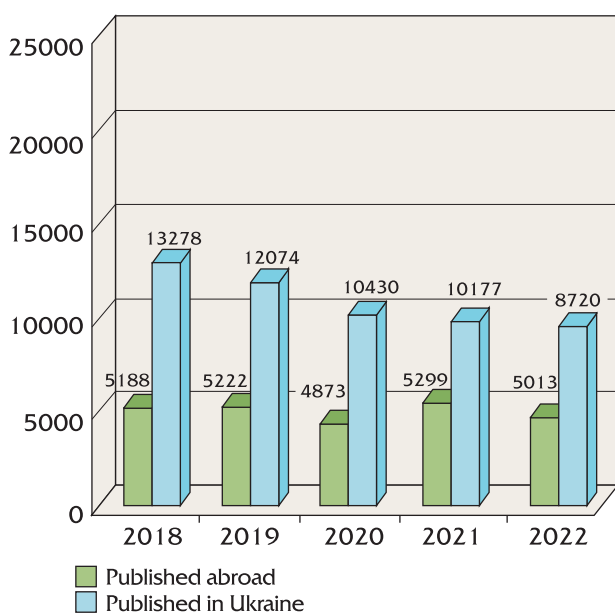

The number of papers by NAS scientists in periodicals

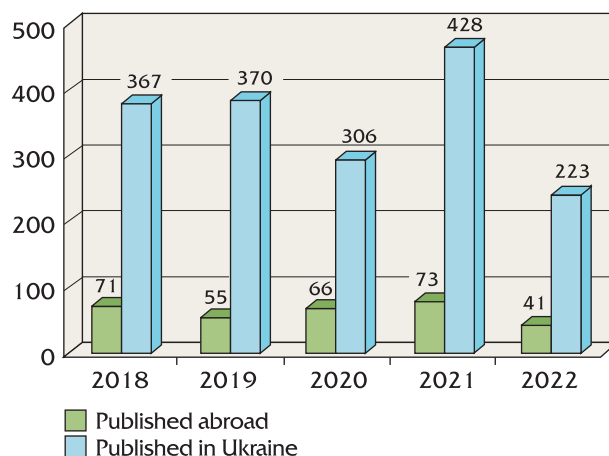

The number of scientific monographs

Publishing activities

- **The total number of Academy journals::**
87 scientific journals, 1 popular-science journal (Svi-tohliad (Worldvision));
- **10 editions are published in English in Ukraine:**
 1. Science and Innovation
 2. Semiconductor Physics, Quantum Electronics & Optoelectronics
 3. Journal of Mathematical Physics, Analysis, Ge-ometry
 4. The Paton Welding Journal
 5. Journal of Thermoelectricity
 6. Ukrainian Journal of Physics
 7. Functional Materials
 8. Biopolymers and Cell
 9. Experimental Oncology
 10. Problems of Cryobiology and Cryomedicine
- **14 journals are published in English abroad:**
 - by Springer Publishers*
 1. Ukrainian Mathematical Journal
 2. Cybernetics and Systems Analysis
 3. International Applied Mechanics
 4. Strength of Materials
 5. Materials Science
 6. Theoretical and Experimental Chemistry
 7. Neurophysiology
 - by Allerton Press Inc.*
 8. Kinematics and Physics of Celestial Bodies
 9. Journal of Superhard Materials
 10. Journal of Water Chemistry and Technology
 11. Cytology and Genetics
 - by Begell House Inc. Publishers*
 12. International Journal on Algae
 13. Hydrobiological Journal
 - by other publishers*
 14. Low Temperature Physics (American Institute of Physics)

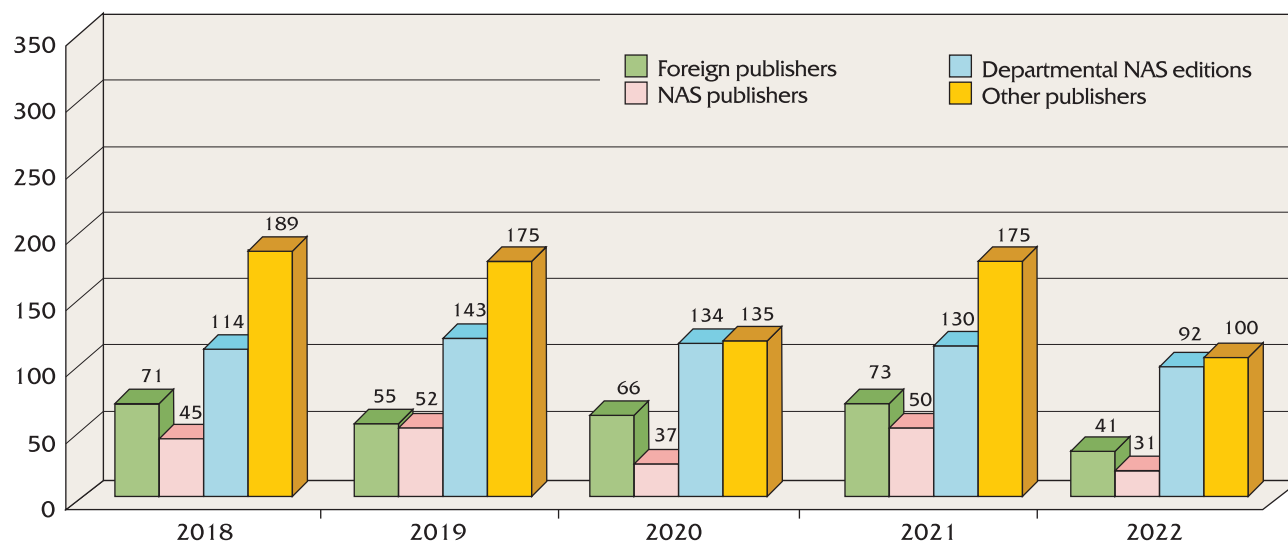

Distribution of scientific monographs across publisher groups

Scientific expert activities

In 2022, NAS scientists were involved in preparing:

- Energy strategy of Ukraine out to 2050;
- Strategy of food security of Ukraine;
- State anti-corruption program 2023—2025;
- Long-term strategy of thermal modernization of buildings out to 2050;
 - National action plan for renewable energy development till 2030;
 - Plan of measures for post-war Ukraine reconstruction and development.

Expert conclusions, notes, proposals were prepared, in particular those concerning the legislation drafts:

- On introducing amendments to the Law of Ukraine "On alternative fuels";

- On cross-border cooperation;
- On introducing amendments to Tax and Customs codes of Ukraine;
 - On accelerated revision of the instruments for state regulation of economic activities;
 - On economic passport;
 - On introducing amendments to the Law of Ukraine "On Ukraine citizenship";
 - On preventing and counteracting the threats to the national security of Ukraine in the sphere of citizenship;
 - On introducing amendments to some laws of Ukraine concerning the ban on using information sources of aggressor country or occupant country in educational programs, in scientific and S&T activities;
 - On introducing changes to some legislative acts of Ukraine concerning the protection and preservation of especially valuable areas of water reservoirs and wares courses.

Expert conclusions	2018	2019	2020	2021	2022
Concerning normative legal acts and program documents, information and analytical materials on various issues of socio-economic development provided for state power bodies	2320	2330	1850	1900	1800
Concerning the expediency of funding basic research projects from the State Budget	393	428	1081	440	412

Innovation activities

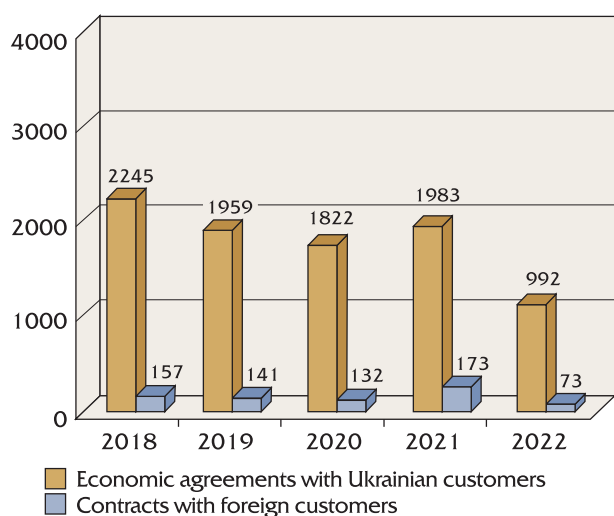

The number of economic agreements and contracts

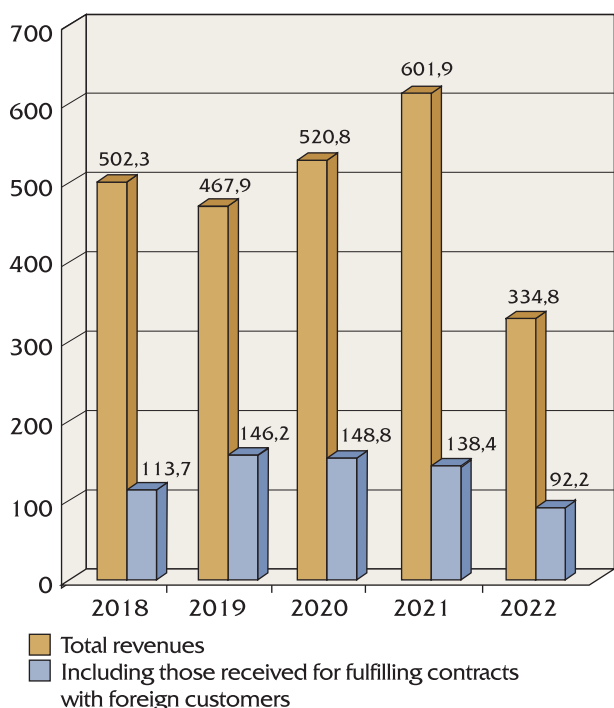

Revenues received by NAS institutions for fulfilling economic agreements and contracts, \$ million

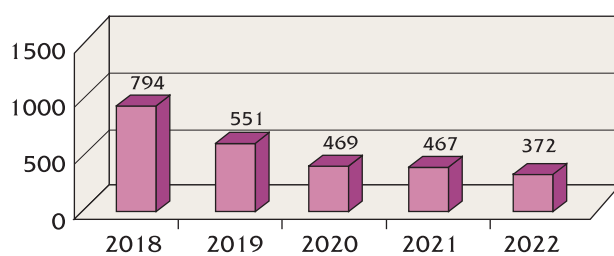

The number of deployed scientific products

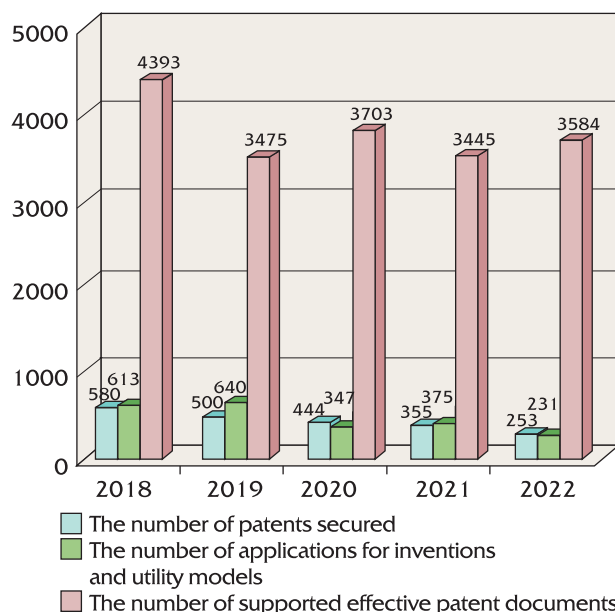

Protection and use of intellectual property objects, the number

Collaboration with institutions of higher education and institutions of the MES of Ukraine

Collaboration agreements concluded by research institutions and institutions of higher education	150
Research topics and projects implemented in collaboration with academics	113
Published monographs co-authored with academics	105
Research scientists who worked in education:	1084
including:	
NAS academicians	36
NAS corresponding members	73
Published textbooks and manuals for institutions of higher education	128
Scientists at the head of chairs in higher education institutions	48
Students of higher education institutions who pursued/are pursuing Master's degree programs at joint research-and-training facilities hosted by scientific organizations::	
in academic year 2021/2022	320
in academic year 2022/2023	300
Students who wrote their graduate papers at research institutions	405
Academics incorporated to specialized academic councils of research institutions	321
Scientists of research institutions incorporated to specialized academic councils of higher education institutions	416

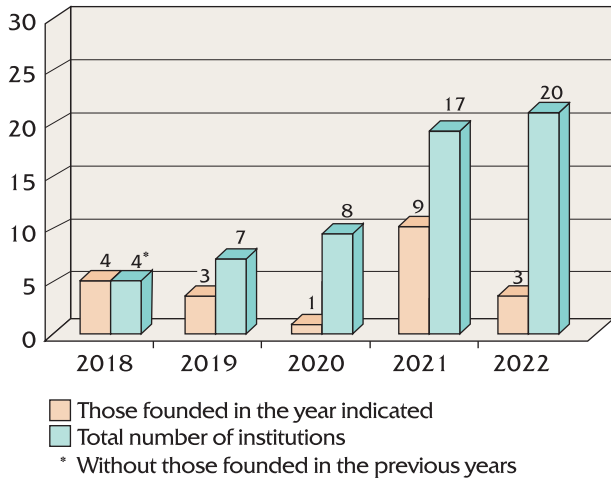

Joint research-and-training facilities

Newly employed graduate specialists who attended study groups of the Junior Academy of Sciences in their school days 9

Research scientists and lecturers of higher education institutions and MES organizations who upgraded their professional skills at research institutions 207

Theses of academics defended at specialized academic councils of scientific research institutions 28

International ties

Legal contractual framework for the international cooperation of the NAS of Ukraine (effective agreements, contracts, memorandums etc.) — a total of 130 documents.

In 2022, the Academy signed:

- Memorandum of understanding between the NAS of Ukraine and Max Plank Society for the Advancement of Science;

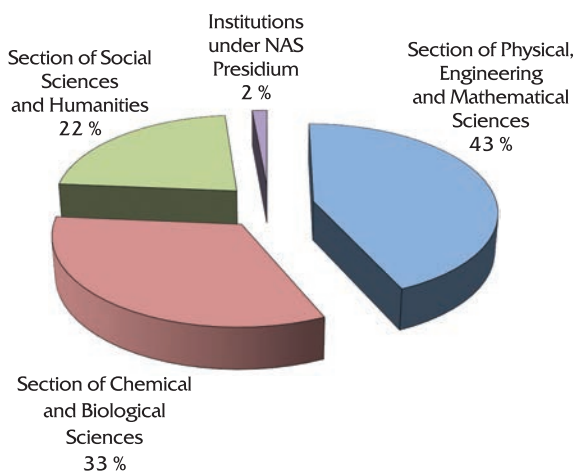

Distribution of direct agreements and contracts across institutions of NAS sections

- Memorandum of understanding between the International Union of Pure and Applied Physics (IUPAP) and the National Academy of Sciences of Ukraine.

Over 600 direct agreements and contracts, concluded by NAS institutions with international partners are in force. Of those, 267 were concluded by the institutions of the Section of Physical, Engineering and Mathematical Sciences, 204 — by the Section of Chemical and Biological Sciences, 137 — by the Section of Social Sciences and Humanities, 9 — by the institutions under NAS Presidium.

Employment figures (as of 01.01.2023)

Total number of employees	26167
of them:	
in research institutions	25028
in research-and-production facilities	903
in service organizations	236
Number of research scientists	13883
of them:	
doctors of sciences	2422
candidates of sciences (PhD)	6487
researchers without an advanced degree	4974
The number of young specialists recruited in 2022	200
The number of those who pursued post-graduate studies	1105
including full-time studies	1000
Defended candidate-of-science (PhD) theses	30
Doctoral fellowships	121
Defended doctor-of-science thesis	7

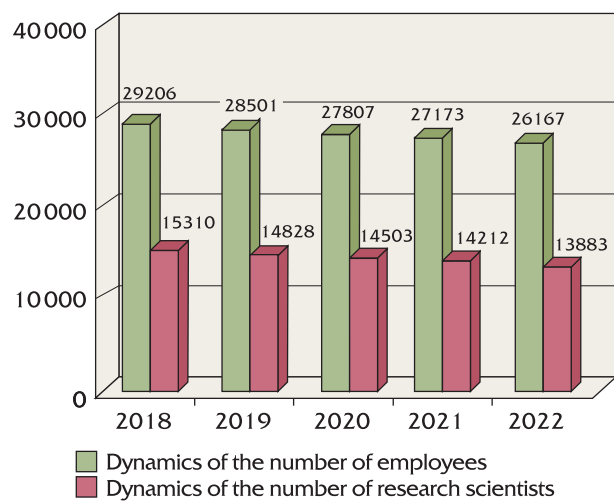

The number of employees

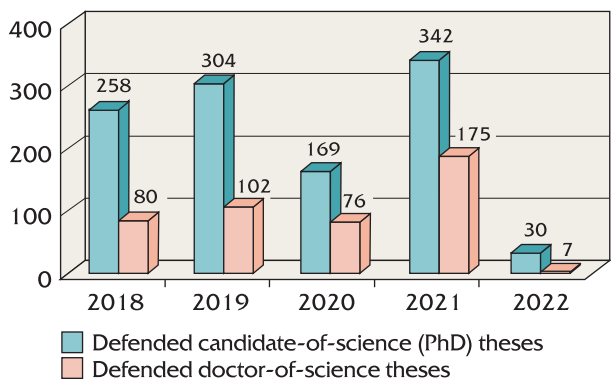

Training of scientific personnel, the number of people

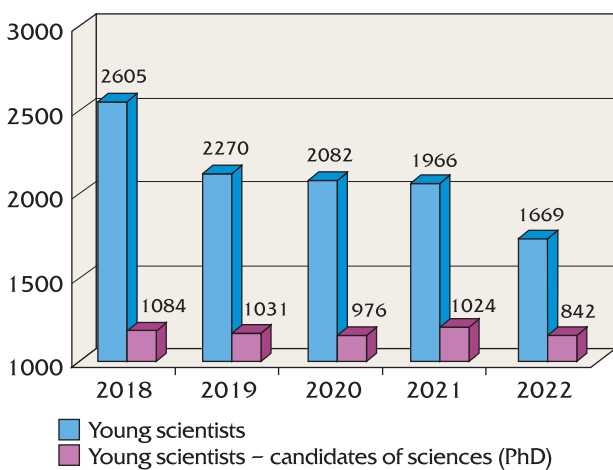

Number of young scientists

Financial provision

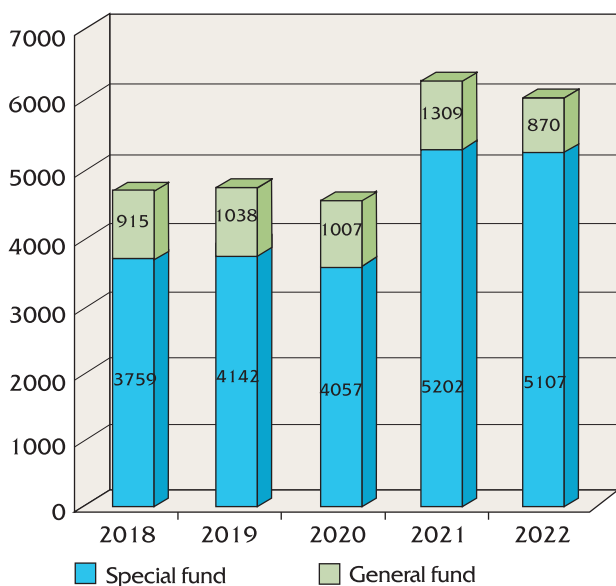

The total amount of NAS funding, ₴ million

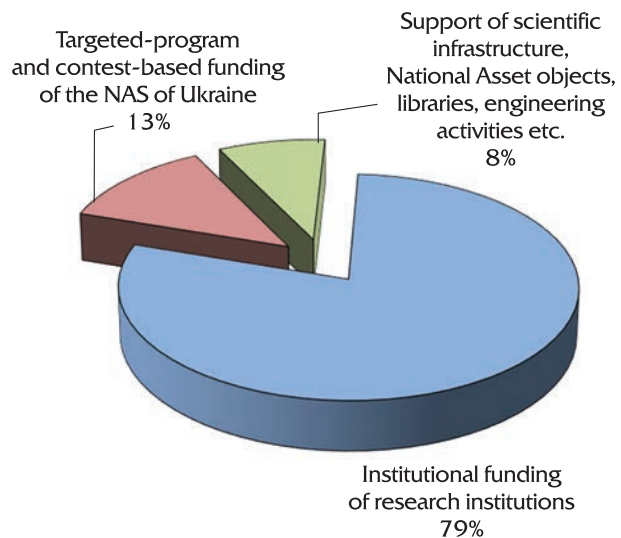

Distribution of general fund finance for conducting scientific research

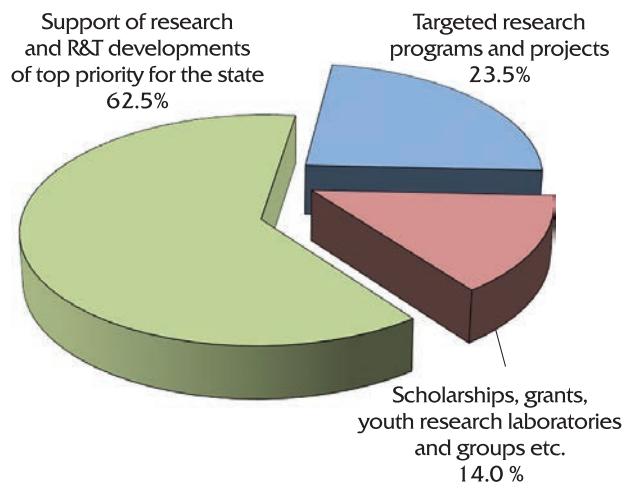

Targeted-program and contest-based funding

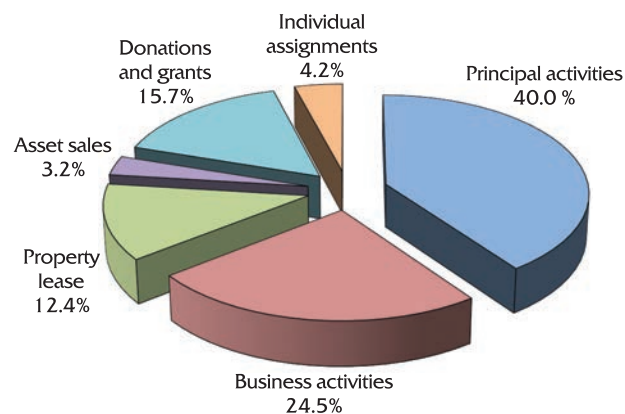

Structure of special fund revenues